



Marvel MR series is a general-purpose battery with 6~8 years design life in float service. It meets with IEC, JIS, BS, GB/T AND YD/T standards. With advanced AGM valve regulated technology and high purity raw material. The Marvel MR series battery maintains high consistency for better performance and reliable standby service life. It is suitable for UPS/EPS, medical equipment, emergency light and security system applications.



MADE IN VIETNAM / CHINA

SPECIFICATION

Cells Per Unit	3
Voltage Per Unit	6
Capacity °C	7.0Ah@20hour-rate to 1.75V per cell @25°C
Weight	Approx. 1.00 Kg (Tolerance±5.0%)
Length	151±1.5mm (5.94 inches)
Width	34±1.5mm (1.34 inches)
Height	94±1.5mm (3.70 inches)
Total Height	100±1.5mm (3.9 inches)
Internal Resistance	Approx. 15 mΩ
Terminal	F1/F2
Max. Discharge Current	70A (5 sec)
Design Life	6~8 years (Float charging)
Maximum Charging Current	2.1 A
Reference Capacity	C3 5.42H
	C5 6.11AH
	C10 6.54AH
	C20 7.00AH
Float Charging Voltage	6.85 V~6.94 V @ 25 Temperature Compensation: -3mV/ °C/Cell
Cycle Use Voltage	7.30 V~7.40 V @ 25 Temperature Compensation: -4mV/ °C/Cell
Operating Temperature Range	Discharge: -20°C~60°C
	Charge: 0°C~50°C Storage: -20°~60°C
Normal Operating Temperature Range	25°C±5°C
Self Discharge	Marvel Valve Regulated Lead Acid (VRLA) batteries can be stored for up to 6 months at 25°C and then recharging is recommended. Monthly Self-discharge ratio is less than 3% at 25°C .Please charged batteries before using.
Container Material	A.B.S. UL94-HB, UL94-V0 Optional.

Dimensions

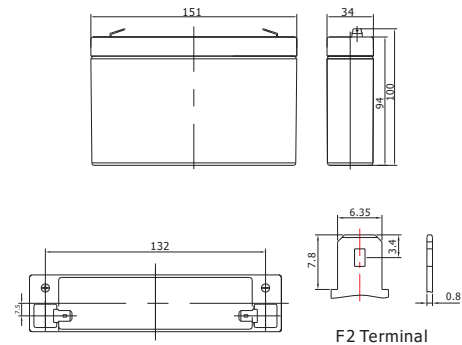

Length	151±1.5mm (5.94 inches)
Width	34±1.5mm (1.34 inches)
Height	94±1.5mm (3.70 inches)
Total Height	100±1.5mm (3.94 inches)
Terminal	Value
M5	6~7 N*m
M6	8~10 N*m
M8	10~12 N*m

Unit: mm

Constant Current Discharge Characteristics :A(25°C)

F. V/Time	5MIN	10MIN	15MIN	30MIN	1HR	2HR	3HR	4HR	5HR	8HR	10HR	20HR
1.60V	26.56	18.77	13.57	7.793	4.277	2.626	1.974	1.594	1.320	0.850	0.690	0.364
1.65V	24.70	17.74	12.97	7.482	4.130	2.542	1.913	1.551	1.286	0.840	0.682	0.359
1.70V	22.28	16.33	12.15	7.151	3.996	2.458	1.861	1.508	1.253	0.827	0.672	0.354
1.75V	19.96	14.95	11.31	6.835	3.850	2.372	1.806	1.470	1.221	0.816	0.663	0.350
1.80V	17.53	13.53	10.44	6.533	3.703	2.288	1.750	1.428	1.190	0.802	0.654	0.347
1.85V	13.91	11.06	8.663	5.627	3.321	2.096	1.618	1.327	1.109	0.753	0.616	0.329

Constant Power Discharge Characteristics : WPC(25°C)

F. V/Time	5MIN	10MIN	15MIN	30MIN	1HR	2HR	3HR	4HR	5HR	8HR	10HR	20HR
1.60V	44.03	31.91	23.72	14.15	8.037	4.977	3.770	3.060	2.545	1.660	1.357	0.718
1.65V	41.42	30.73	23.01	13.73	7.806	4.841	3.669	2.988	2.489	1.645	1.342	0.707
1.70V	38.22	28.81	21.88	13.26	7.599	4.708	3.585	2.918	2.432	1.623	1.324	0.700
1.75V	35.00	26.85	20.65	12.80	7.366	4.564	3.493	2.854	2.379	1.604	1.308	0.692
1.80V	31.39	24.73	19.34	12.36	7.125	4.423	3.398	2.782	2.326	1.580	1.293	0.686
1.85V	25.44	20.57	16.28	10.75	6.430	4.075	3.156	2.595	2.176	1.487	1.219	0.652

(Note) The above characteristics data are average values obtained within three charge/discharge cycle not the minimum values. The battery must be fully charged before the capacity test. The Cm should reach 95% after the first cycle and 100% after the third cycle.

Discharge Characteristics Curve

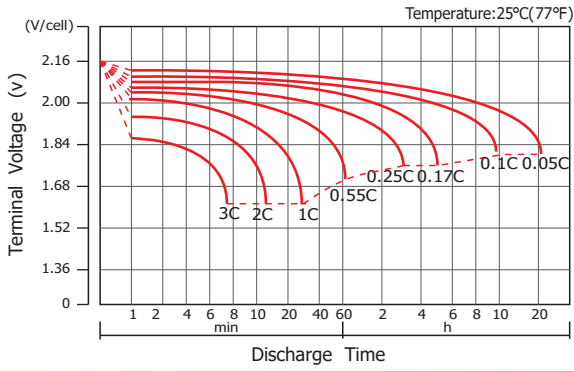

Charge Characteristic Curve For Standby Use

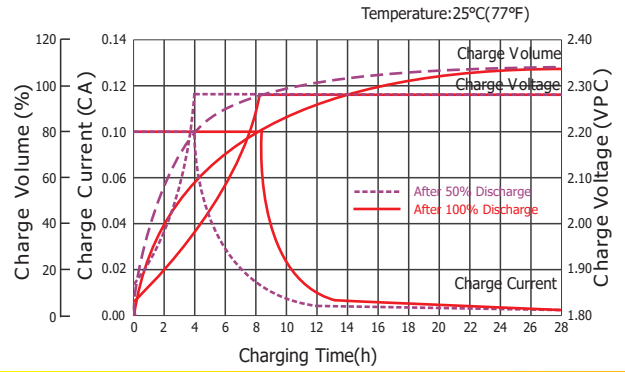

Cycle Life In Relation To Depth Of Discharge

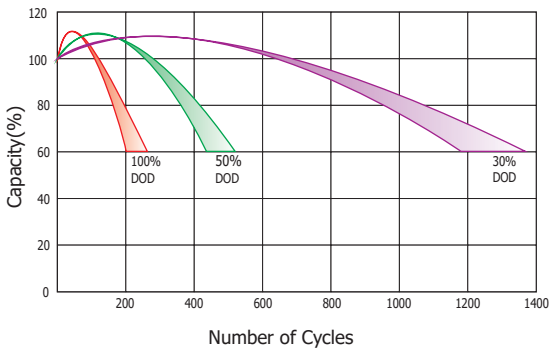

Relationship Between Charging Voltage And Temperature

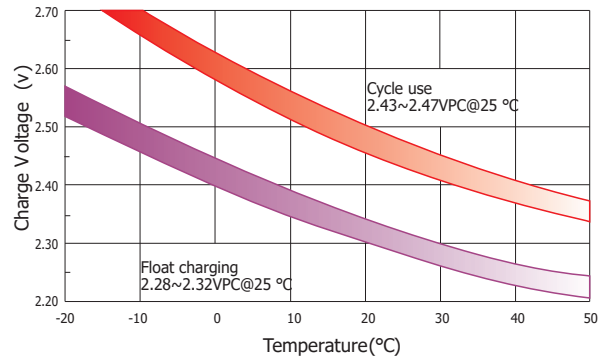

Temperature Effects On Capacity

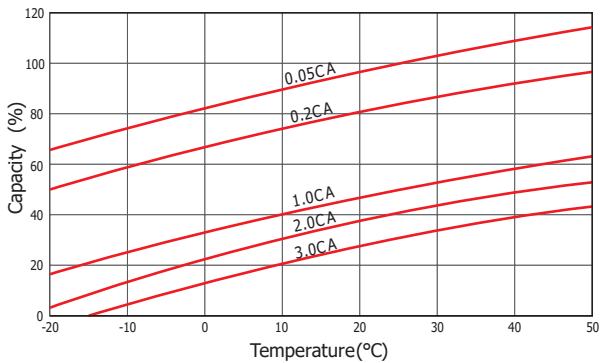

Storage Characteristics

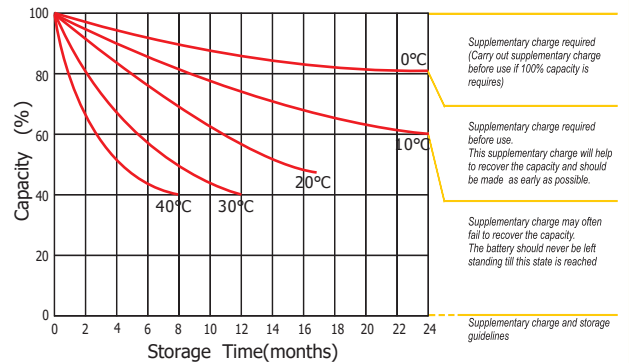

Effect Of Temperature On Long Term Life

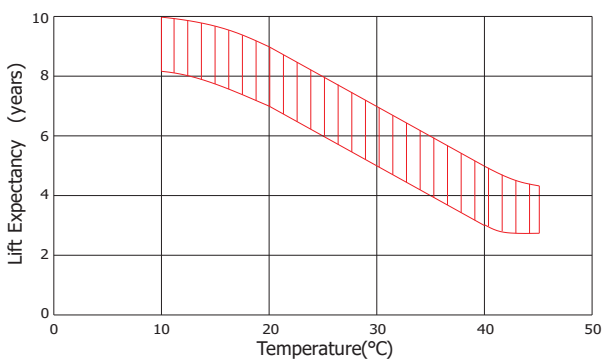

Life Characteristics Of Standby Use

