



LifePO4 Battery
ML280-51.2
User Manual

Contents

1 Safety Information	1
1.1 Symbols	1
1.2 Safety Instructions.....	2
1.2.1 General Safety Precautions	2
1.2.2 Battery Handling Guide	2
1.2.3 Response to Emergency Situations	3
1.3 Qualified Personnel.....	3
2 Product Introduction	4
2.1 General Information	4
2.2 Product Features.....	4
2.3 Apperence and Mechanical Drawing	5
2.4 Electrical Performance	5
2.4.1 Battery Pack Parameters.....	5
2.4.2 BMS and Display	6
2.5 Transportation and Storage	8
2.5.1Transportation	8
2.5.2 Storage.....	8
3 Installation	9
3.1 Install Location	9
3.2 Tools/Safety Gears Required.....	9
3.2.1 Tools	9
3.2.2 Safety Gears For Personal Protection.....	9
3.3 DC Cable Prepared.....	10
3.3.1 Choose DC Cable	10
3.3.2 Fabrication of DC Cable	10
3.4 Battery Pack Installation	10
3.4.1 Battery Installation.....	11
3.4.2 System Installation Guide.....	12
4 Commissioning and operation	12
4.1 Operating Conditions	12
4.2 Battery Commissioning Steps.....	12
4.3 Communication Protocol Setting	13
4.3.1 Setting By BMS Host Software(PC).....	13
4.4 Communication with INVERTER or MPPT.....	15
4.4.1 Master/RS485/CAN Ports Introduction.....	15
4.4.2 Dial switch setting.....	16
5 Troubleshooting.....	17
6 Liability Limitation	17

1 Safety Information

1.1 Symbols



Caution, risk of electric shock



Do not place or install near flammable or explosive materials



Install the product out of reach of children.



Read the instruction manual before starting installation and operation.



Heavy weight may cause serious injury to the back.



Do not dispose of the product with household wastes.



Recyclable



Disconnect the equipment before carrying out maintenance or repair.



Observe precautions for handling electrostatic discharge sensitive devices.

1.2 Safety Instructions

For safety reasons, installers are responsible for familiarizing themselves with the contents of this document and all warnings before performing installation.

1.2.1 General Safety Precautions

Over-voltages or wrong wiring can damage the battery and cause deflagration, which can be extremely dangerous.

All types of breakdowns of the product may lead to a leakage of electrolyte or flammable gas.

Avoid installing the battery where flammable materials are stored. Do not install in places where explosive gas or chemicals are present.

The utility grid, solar input, and battery voltage must be disconnected from the battery wiring. Wiring must be carried out by a qualified person.

Lithium battery is not user serviceable.

1.2.2 Battery Handling Guide

Do not expose battery to open flame.

Do not place the product nearby flammables. It may lead to fire or explosion in case of accident.

Do not expose or place near water sources like downspouts or sprinklers.

Do not store this product in a place exposed to direct sunlight.

A ventilated area is strongly recommended for handling the product.

Store at cool and dry place. (Do not store in greenhouses and storage areas for hay, straw, chaff, animal feed, fertilizers, vegetables or fruit products.)

Store the product on a flat surface.

Store the product out of reach of children and animals.

Store the product where it should be minimal dust and dirt in the area.

Do not disconnect, disassemble or repair by unqualified personnel. Service must be made by qualified personnel only.

Do not damage the unit in such ways as dropping, deforming, impacting, cutting or penetrating with a sharp object. It may cause a leakage of electrolyte or fire.

Do not touch if liquid is spilled on the product. There is a risk of electric shock. Handle the battery wearing the insulated gloves.

Do not step on the product or the product package. The product may be damaged.

Do not place any foreign objects on the top of the Battery Pack.

Do not put the battery pack upside down on the ground.

Do not connect anode and cathode terminal block opposite direction.

Do not charge or discharge damaged battery.

If the battery pack is installed in the garage then ensure the product is above the height of the vehicle bumper.

The battery pack only be installed indoors. If installed outdoors, do not allow the battery pack to be exposed to direct sunlight and water source as it may cause:

- Power limitation phenomena in the battery

(With a resulting decreased energy production by the system)

- Premature wear of the electrical/electromechanical components and mechanical components.

- Reduction in performance, service life and possible damage of the battery

Only use the product with supplier recommend inverter and solar charge controller (MPPT) .

Do not connect any AC conductors or Photo-voltaic conductors directly to the battery pack and should be only connected to the Inverter and solar charge controller (MPPT) .

1.2.3 Response to Emergency Situations

The battery comprises multiple batteries and Sophisticated BMS that are designed to prevent hazards resulting from failures. However, we cannot guarantee their absolute safety if battery is mishandled. If a user happens to be exposed to internal materials of the battery cell due to damage on the outer casing, the following actions are recommended.

Inhalation: Leave the contaminated area immediately and seek medical attention.

Eye contact: Rinse eyes with running water for 15 minutes and seek medical attention.

Contact with skin: Wash the contacted area with soap thoroughly and seek medical attention

Ingestion: Induce vomiting and seek medical attention.

If a fire breaks out in the place where the battery pack is installed, perform the following countermeasures:

Fire extinguishing media

Respirator is not required during normal operations.

Use FM-200 or CO₂ extinguisher for battery fire.

Use an ABC fire extinguisher, if the fire is not from battery and not spread to it yet.

Firefighting instructions

If fire occurs when charging batteries, if it is safe to do so, power off the switch.

If the battery pack is not on fire yet, extinguish the fire before the battery pack catches fire.

If the battery pack is on fire, do not try to extinguish but evacuate people immediately

Effective ways to deal with accidents

On land: Place damaged battery into a segregated place and call local fire department or service engineer.

In water: Stay out of the water and do not touch anything if any part of the battery, inverter, or wiring is submerged.

Do not use submerged battery again and contact the service engineer.

1.3 Qualified Personnel

This guide and the tasks and procedures described herein are intended for use by skilled workers only. A skilled worker is defined as a trained and qualified electrician or installer who has all of the following skills and experience:

Knowledge of the functional principles and operation of on-grid and off-grid (backup) systems.

Knowledge of the dangers and risks associated with installing and using electrical devices and acceptable mitigation methods.

Knowledge of the installation of electrical devices

Knowledge of and adherence to this guide and all safety precautions and best practice



Make sure all power is off and wires are disconnected when maintaining/servicing the battery

2 Product Introduction

2.1 General Information

The power cube battery system is a high-tech product researched and developed product. With its integration, miniaturization, light-weight, intelligent centralized monitoring, battery maintenance and management, unattended, energy conservation and environmental protection, are widely applied in remote access network equipment, remote switch unit, mobile communication, transmission equipment, home storage and other areas as a backup power supply.

2.2 Product Features

- The battery adopts LiFePO₄ as cathode material; LiFePO₄ cell life cycle could reach 10000 times at 80% DOD and 70%EOL@25°C.
- The system adopts high performance of BMS battery management module. The BMS has the protection function in current, voltage and temperature, it also makes a good communication between battery system and the host equipment;
- Monitoring unit will automatically measure the battery charge and discharge current, charge and discharge voltage, single cell surface temperature;
- Auto-power cut off function. It will have the alarm information if the battery voltage is lower than the alarm value, when the voltage is too low, it will protect the batteries by automatic power cut off;
- The system has a good electromagnetic compatibility;
- All intelligent design, equipped with centralized monitoring module, it realizes the computer management which can communicate with the remote central control center;
- Effective combinations of Power control technology with computer which realize real-time monitoring and control all kinds of parameters and state;
- The battery owns Bluetooth and APP functions;
- Up to 15 batteries can be connected in parallel.
- Flexible installation: Indoor



The operation manual is a general text, and not all products have all the functions or features listed in the manual. Please consult your local retailer at the time of purchase.

2.3 Appearance and Mechanical Drawing

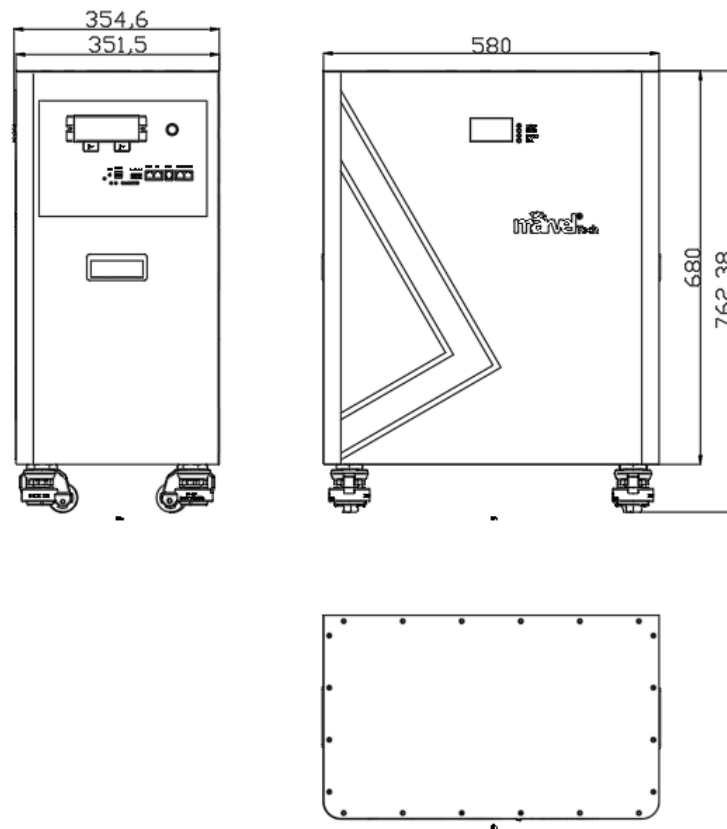

Tips: The specific dimensions are subject to the actual items received, and the dimensions of some models of batteries are not listed.

2.4 Electrical Performance

2.4.1 Battery Pack Parameters

Battery Technology Specification		
NO	Model	ML 280 – 51.2V
1	Battery Rated Voltage	51.2 Vdc
2	Battery Rated Capacity	280Ah
3	Battery Rated Energy	14.34KWh
4	Battery Cell Type	Long Cycle Life Prismatic LiFePO4
5	Rated Charge Voltage	56Vdc
6	Max Charge Voltage	56.8Vdc
7	Overcharge Protection	57.6Vdc
8	Rated Charge Current @RT	140A
9	Recommended Charge current	84A
10	Max Charge Current @RT	150
11	Over Charge Protection Release	Restart or Protection Release
12	Charge Temp Range	0~45°C, (RT=25°C)
13	Output Voltage Range	44.8~56.8Vdc

14	Rated Discharge Current @ RT	140
15	Max Discharge Current @RT	155A@8S
16	Over Discharge Protection Release	Charging or Cut off loads and Restart
17	Discharge Temp Range	-10~55°C, (RT=25°C)
18	Weight	120kg
19	Size	763*580*355mm
20	Bluetooth & App	No
21	Display	LCD
22	Parallel Function	Yes
23	Communication	RS485 /CAN

2.4.2 BMS and Display

The batteries are supplied with a LiFePO4 Battery Management System (BMS) that can monitor and optimized each single prismatic cell during charge & discharge, to protect the battery pack overcharge, over discharge, short circuit. Overall, the BMS helps to ensure safe and accurate running.

Battery supports up to 15 batteries in parallel. However, it is not recommended to connect more than 4 batteries in parallel for safety or local electrical rules.

The product models are as follows: **ES-H48280B**

BMS content display in battery LCD, the details are as below:

1) Main menu page

After power-on/spin-down is activated, the Welcome screen is displayed. Press the "MENU" key to enter the main "MENU" page.

As shown in the picture below:

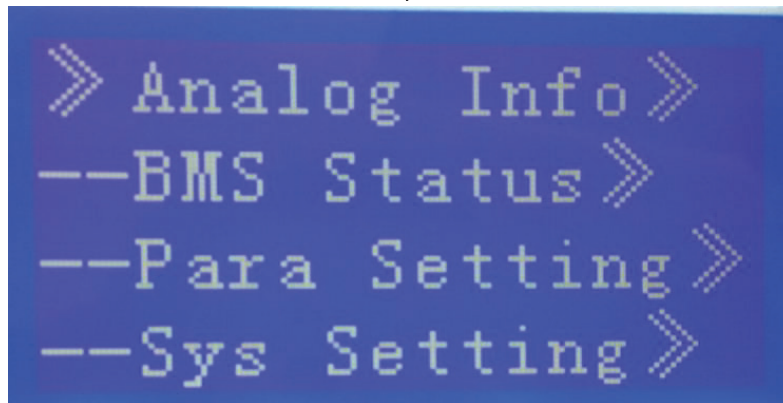

2) Battery parameter collection page

When the cursor "»" points to "battery parameter collection", press ENTER to ENTER the "battery parameter collection" page, as shown in the picture below:

```
>> PackV: 0.00 V
--Im: 0.00 A
--Temperature >>
--Cell Voltage >>
```

3) Button instruction

- SW1----MENU, SW2----ENTER, SW3----DOWN, SW4----ESC.
- Each item starts with ">>" or "--", where ">>" indicates the current cursor position. Press "DOWN" to move the cursor position "DOWN". If the item ends with ">>", it indicates that the item has undisplayed content. Press "ENTER" to go to the corresponding page.
- Press "ESC" to return to the upper-level directory. From any location, press the "MENU" key to return to the main "MENU" page.
- In the sleep state, press any key to activate the display.

```
Welcome To Use
Smart BMS
-----
Press MENU Key
```

- MENU
- ENTER
- DOWN
- ESC

2.5 Transportation and Storage

2.5.1 Transportation

Based on the character of cell, proper environment for transportation of LiFePO₄ battery pack need to be created to protect the battery. Battery should be stayed in the ware house -20°C~35°C where is dry, clean, shade, and well-ventilated. The battery should be stored in 45~55% SOC during transportation.

Product is adapted to the truck, boat, transport. When transport, it should be covered to avoid the sunlight, and with civilized loading and unloading. Packaged products are allowed to be transported by any kind of vehicles or boats. The battery shall be handled with care during loading and unloading to prevent throwing, rolling and pressing. Rain and snow shall be avoided during transportation.

2.5.2 Storage

The products shall be stored in a dry warehouse and shall not be exposed to the sun and rain. Harmful gases, inflammable and explosive products and corrosive chemicals are not allowed in the warehouse. The product shall avoid mechanical impact, stress and strong magnetic field effect. The product shall be protected from direct sunlight, and the distance from the heat source shall not be less than 2m. The product packing box shall be at least 20 cm above the ground and at least 50 cm away from the wall, window or air inlet.

Tips: Under the provisions of the conditions of storage period of more than 3 months of products should charge once, storage period of more than 6 months products must check and test the capacity, store for more than 1 years of products must be re-examined, only can be used when is qualified.

1	Storage Temperature	Less than 1 month	-20~35°C
		Less than 6 months	-10~30°C
2	Storage humidity	45~75%RH	

3 Installation

3.1 Install Location

Required:

There must be no flammable or explosive materials nearby.

The recommended ambient temperature should be within the range of -10 ~45°C.

Battery pack must be installed on walls that are upright and can support battery weight.

Product shall be installed indoor.

Recommended:

The building should be designed to withstand earthquakes.

The install position should be waterproof and properly ventilated area.

Install the product on a flat wall, surface or heavy-duty cabinet. Use proper supports, brackets and/or straps to handle the weight of the battery.

Install the product out of reach of children and animals.

CAUTION!

If the ambient temperature is outside of the operating range, the battery pack may stop operating to protect the internal components. The optimal temperature range for the battery pack to operate is from 10°C to 30°C . Frequent exposure to harsh temperature es may deteriorate the performance and overall life of the battery and will void the warranty.

3.2 Tools/Safety Gears Required

3.2.1 Tools

The following tools are required to install the battery pack



Precision screwdriver

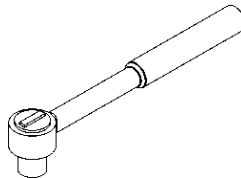

M8 & M10 Torque wrench

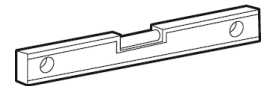

Inclinometer



Drill



Pencil or Marker

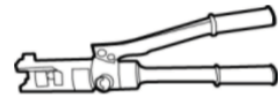

Hydraulic Tongs

3.2.2 Safety Gears For Personal Protection

It is recommended to wear the following safety gears when handling the battery pack.



Insulated gloves



Safety goggles



Safety shoes

NOTE

The product is heavy and challenging to lift. Lift handles are recommended.

3.3 DC Cable Prepared

3.3.1 Choose DC Cable

It is suggested the battery pack be kept as close as possible to the inverter or DC load. The following is a suggested wiring option for 1meter DC cable.

Please find the following minimum wire size, in case of DC cable longer than 1m, please increase the cross section of cable to reduce the loss.

NO.	Model	DC Output voltage	Wire Gage
1	ES-H48280B	51.2 Vdc	AWG 1/0#

Performance of any product can be improved by thicker cable and shorter runs, so if in doubt, round up and keep the length as short as possible.

For more wiring configurations for your specific system, please contact your distributor for more information.

WARNING

The torque rating range for DC terminal is 9NM-12NM, and the suggested torque rating is 9NM. Over torquing may cause the bolt to break.

3.3.2 Fabrication of DC Cable

You can choose a DC cable manufacturing method according your battery or inverter connection ports.

a) Copper o-terminal

Manufacturing steps of battery connected power DC line:

Step 1: select the battery model, select the corresponding model wire, and peel off the front section of the cable for 15mm;

Step 2: use the corresponding M8 or M6 o-terminal;

Step 3: insert the stripped wire into the o-terminal and press it tightly with the crimping fixture;

Step 4: select the box terminal crimping according to the model of circuit breaker between inverter and battery;

Step 5: install the connecting wire according to the requirements of Chapter3.4.3 (reverse connection of positive and negative wires is strictly prohibited).

Step1,2,3.



Tips: The holding force of the harness after riveting is $50\text{mm}^2 \geq 1800\text{Nmin}$; If the holding force is insufficient or the terminal is excessively extended, please adjust the riveting size appropriately.

3.4 Battery Pack Installation

CAUTION!

Make sure that the inverter AC and DC disconnects are turned off before connecting the power cable to the battery pack.

NOTE!

USE PROPER BRACKETS, SUPPORTS, AND/OR STRAPS TO HANDLE THE WEIGHT OF THE BATTERY. WELL VENTILATED, HEAVY DUTY BATTERY CABINET IS RECOMMENDED.

3.4.1 Battery Installation

Step1: Remove the product from the outer packing box to ensure that the bottom four wheels hit the product floor, and move the product in place.

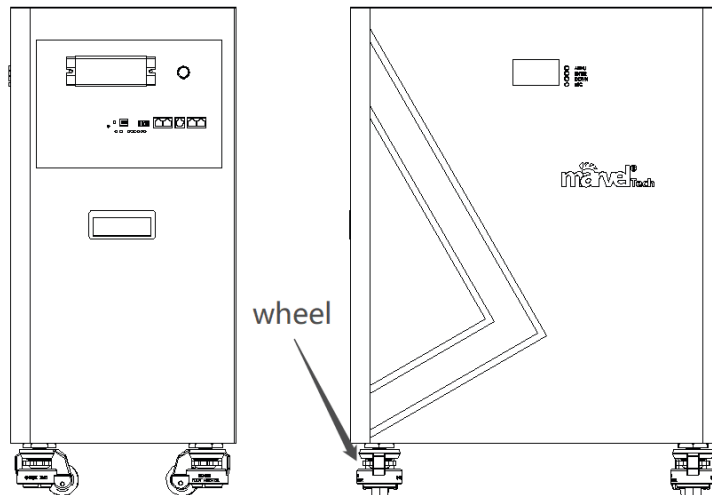

Installation Size

Step2: Turn the red part of the four wheels to make the black support column fall and contact the ground until the wheel leaves the ground. Adjust the height of the four supports to ensure the smooth product placement.



Other model of batteries can be installed according to the site conditions or consulting local retailer.

3.4.2 System Installation Guide

Connect the parallel batteries with wires according to the following schematic diagram (the following is a operation diagram of two parallel batteries)

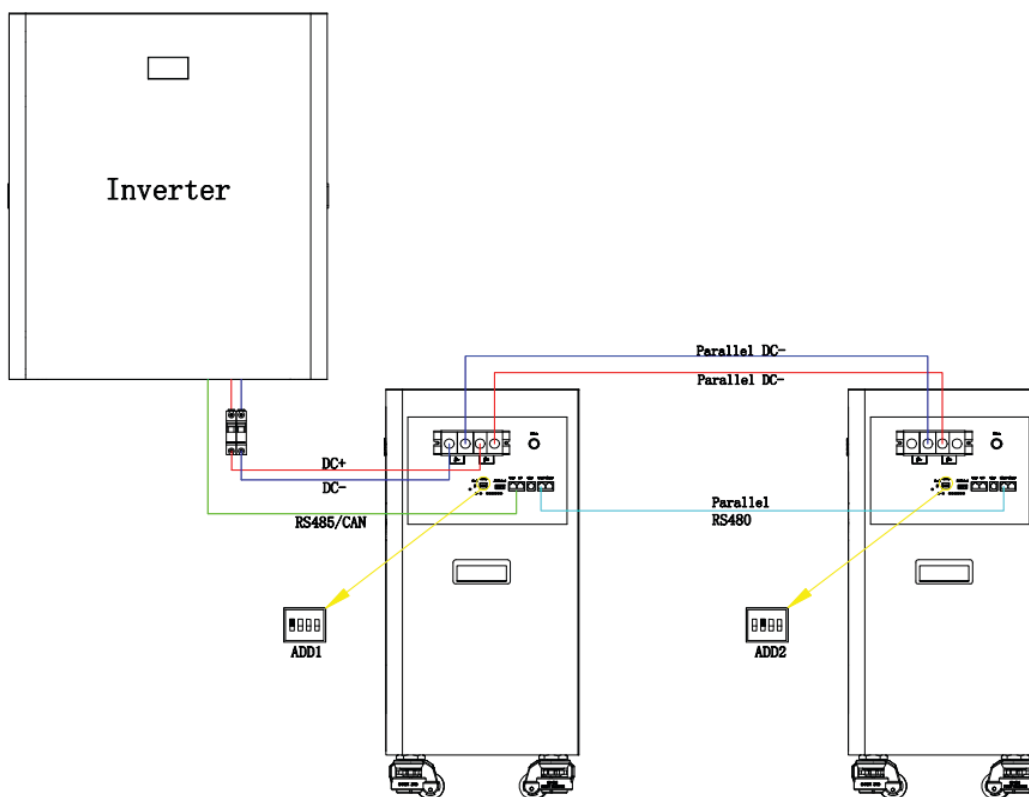

System Connection Diagram

4 Commissioning and operation

4.1 Operating Conditions

Installation Location	Indoor (Wall-Mounted or Flat-Mounted)
Operating Temperature	14 to 113°F (-10 to 45°C)
Operating Temperature (Recommended)	59 to 86°F (15 to 30°C)
Humidity	15% to 85%
Altitude	Max. 6,562ft (2,000m)
Cooling Strategy	Natural Convection

4.2 Battery Commissioning Steps

Step 1: Check whether the battery power line is connected correctly, whether the connecting nut is fastened in place and whether the inverter part is connected normally.

Step 2: Check whether the communication harness is connected normally as required

Step 3: Setting a corresponding communication protocol between and battery and inverter. (Please see 4.3 Communication Protocol Setting)

Step 4: Set the dial switch: when the host battery communicates with an inverter, the address of the

host battery shall be set to 1, and other parallel batteries shall be set in sequence (Please see 4.4.2 dial switch setting)

Step 5: After the preparation is completed, turn on the battery switch → circuit breaker → inverter load switch in sequence

Step 6: Check whether the system works normally. If it is abnormal, check it in sequence or contact the local dealer.

CAUTION

1. Please strictly follow the above steps for debugging
2. If not using the battery pack for a long time or if there is any fault on the pack, turn off the power switch.

4.3 Communication Protocol Setting

You can choose the below two ways to select your matched inverter communication protocol.

4.3.1 Setting by BMS Host Software (PC)

The product models are as follows:

ES-H48280B

BMS Host software need to install with PC. Log in to our website or consult the local dealer to obtain the BMS upper computer software, but we suggest that the upper computer software should be used by professional installers.

BMS can communicate with the upper computer through the RS232 interface to monitor various information of the battery through the upper computer, including battery voltage, current and temperature Degree, status and battery production information, the default baud rate is 9600bps.

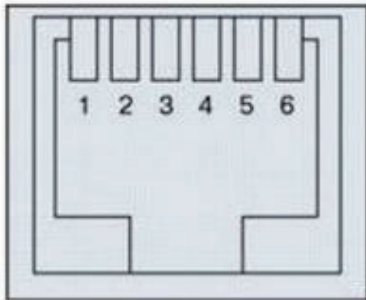

RS232-6P6C-RJ11	
RJ11 Pin	Definition
3	TX
4	RX
5	GND
1, 2, 6	NC

RS232 Port Define

1. RS232 communication line connection



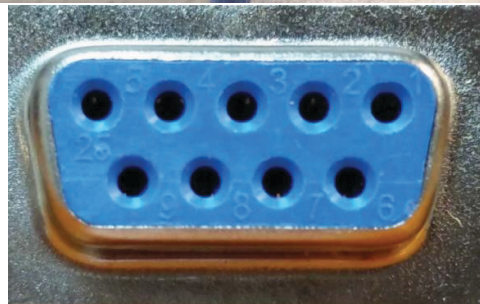

1. As shown in the figure above, the left end of the crystal head has one foot. 3 (green) 4 (white) 5 (blue) feet correspond to 2, 3 and 5 feet of DB9 head Please ensure that each pin of the communication line is connected. The best way is to measure with a multimeter.

2. The crystal head is connected to the 232 interface of the protection board, and the USB end is connected to the USB port of the computer

2. Connect to the upper computer

STEP1. Ensure that the protection board is powered on and not hibernated. Insert the RJ45 connector of the communication cable into the communication port on the protection board. The USB terminal is inserted into the USB port of the computer.

STEP2. Double-click to open the upper computer software :

- 1、 Select RS232 for the serial port on the computer.
- 2、 Click "Open the serial port".
- 3、 Click "on Start Monitoring".

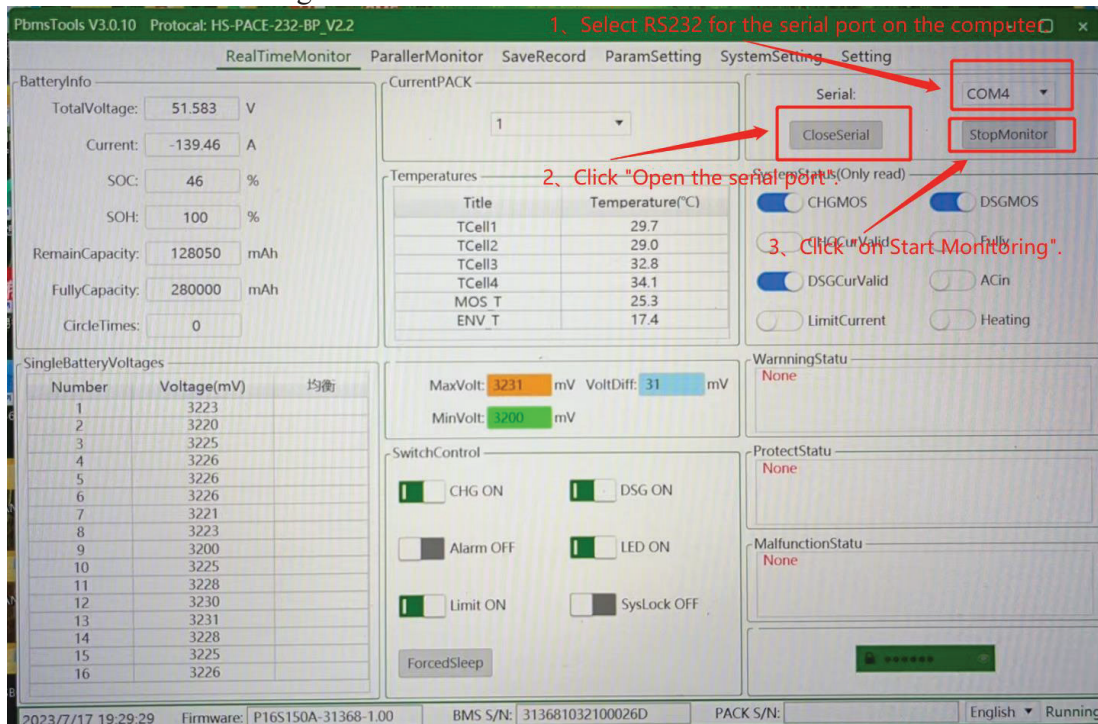

4.4 Communication with INVERTER or MPPT

Before using the battery system, the inverter, the MPPT and the battery system must be connected by communication lines. Connect the RS485 communication port of the battery pack to the inverter and MPPT, After all external wiring harnesses are connected, they can work normally after starting up.

The battery has two independent RS485 isolated communication interfaces, and the default communication baud rate is 9600bps. One RS485 interface is used as the internal communication port for battery parallel (RS485 port) or to view the detailed information of the battery through the host computer software (Master port). One RS485 interface is used for external inverter communication, and this port can also be used as the CAN communication port (CAN/RS485 port).

4.4.1 Master/RS485/CAN Ports Introduction

- Internal Master/RS485 parallel communication port. As shown in the below :

RS485A1 RS485A2

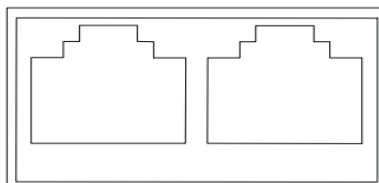

Master/RS485 to Parallel Port

Parallel/RS485 Port Define

RS485-8P8C-RJ45	RS485-8P8C-RJ45
-----------------	-----------------

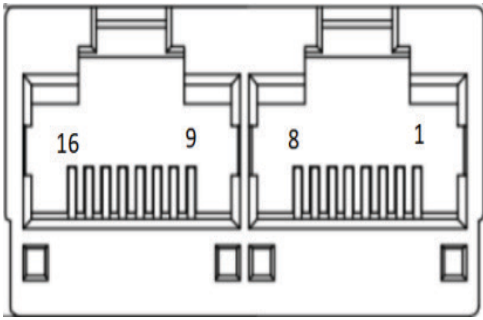

RJ45 Pin	Definition	RJ45 Pin	Definition
1, 8	RS485-B	9, 16	RS485-B
2, 7	RS485-A	10, 15	RS485-A
3, 6	GND	11, 14	GND
4, 5	NC	12, 13	NC

• Connected externally to the inverter communication port of RS485/CAN. It can be compatible with multiple inverter protocols. As shown in the figure below:

RS485 CAN

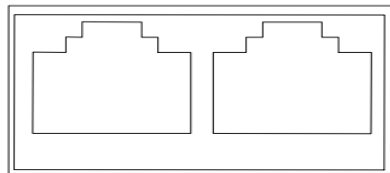

CAN/RS485 Port Define

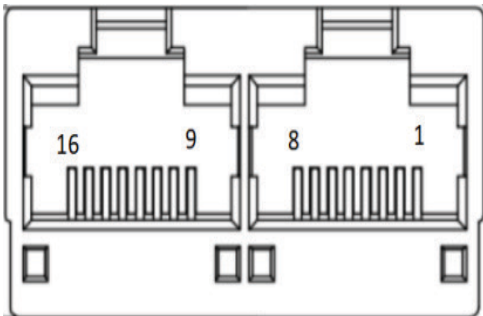

RS485-8P8C-RJ45		RS485-8P8C-RJ45	
RJ45 Pin	Definition	RJ45 Pin	Definition
1, 8	RS485-B	9, 10, 11	NC
2, 7	RS485-A	12, 13, 14, 16	NC
3, 6	GND	15	GND
4	CANH	5	CANL

NOTE: Communication line is required for RS485 or CAN communication.

4.4.2 Dial switch setting

When the battery is connected to the PC host, the address should be set to 0 to communicate with the PC host computer;

When the battery is used in parallel, set the address through the dial switch on the battery to distinguish different addresses. It is necessary to avoid setting the address to the same.

When the battery communicates with the inverter (or controller), the address of the corresponding battery connected to the inverter (controller) must be set to 1, otherwise the communication cannot be established

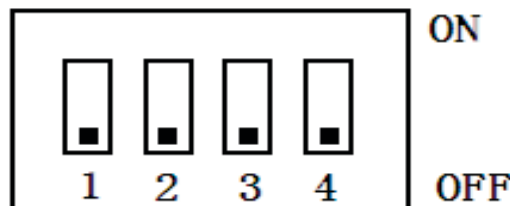

Dial switch interface

The details of setting method is shown in the table below:

NO.	Module Address	BMS Module ID	ID Arrangement			
			1#	2#	3#	4#
1	0x01	1	ON	OFF	OFF	OFF
2	0x02	2	OFF	ON	OFF	OFF
3	0x03	3	ON	ON	OFF	OFF
4	0x04	4	OFF	OFF	ON	OFF
5	0x05	5	ON	OFF	ON	OFF
6	0x06	6	OFF	ON	ON	OFF
7	0x07	7	ON	ON	ON	OFF
8	0x08	8	OFF	OFF	OFF	ON
9	0x09	9	ON	OFF	OFF	ON
10	0x0A	10	OFF	ON	OFF	ON
11	0x0B	11	ON	ON	OFF	ON
12	0x0C	12	OFF	OFF	ON	ON
13	0x0D	13	ON	OFF	ON	ON
14	0x0E	14	OFF	ON	ON	ON
15	0x0F	15	ON	ON	ON	ON
0	0x00	0	OFF	OFF	OFF	OFF

5 Troubleshooting

Check the indicators on the front of the battery to determine the status of the battery pack. A warning state is triggered when a condition, such as voltage or temperature, is outside battery's rating. When the battery pack status falls outside of set limits, it enters a warning state. When a warning is reported, turn off the DC source immediately.

Use the monitoring software to identify the cause of the warning.

Warning Alarms

Battery Over Voltage

Battery Under Voltage

Battery Over Temperature

Battery Under Temperature

Battery Discharge Over Current

Battery Charge Over Current

The fault state is cleared when the battery pack recovers to normal operation. If battery pack is not working correctly and the issue persists, contact a qualified technician or your distributor.

If the battery pack or the inverter indicates FAULT or fails to operate, contact your distributor immediately.

6 Liability Limitation

Any product damage or property loss caused by the following conditions does not assume any direct or indirect liability.

Product modified, design changed or parts replaced without authorization;

Changes, or attempted repairs and erasing of series number or seals by non-technician;

System design and installation are not in compliance with standards and regulations;

Failure to comply with the local safety regulations;

Transport damage (including painting scratch caused by rubbing inside packaging during shipping). A claim should be made directly to shipping or insurance company in this case as soon as the container/package is unloaded and such damage is identified;

Failure to follow any/all of the user manual, the installation guide and the maintenance regulations;
Improper use or misuse of the device;
Insufficient ventilation of the device;
The maintenance procedures relating to the product have not been followed to an acceptable standard;
Force majeure (violent or stormy weather, lightning, overvoltage, fire etc);
Damages caused by any external factors.

