



# ML16K-HVR-07 user manual

# CONTENT

1. Important information in the manual .....	3
1.1 Scope .....	3
1.2 Description .....	3
1.3 Meaning of Symbols .....	4
1.4 General Safety Information .....	6
1.5 Disclaimer .....	6
1.6 Installation environment .....	6
1.7 Requirements for Installation Personnel .....	8
2. Safety .....	9
2.1 Safety rules .....	9
2.2 Safety information .....	9
3. Transport to the end customers .....	9
3.1 Provisions on Shipping of Battery Modules: .....	9
3.2 Permissible and Impermissible Storage Positions of a Packaged Battery Module	10
4. Description and installation of battery .....	11
4.1 Installation Precautions .....	11
4.2 Product Description .....	11
4.3 Technical Data .....	11
4.4 Description of Battery Module .....	13
4.5 Description of high-voltage BMS box .....	14
List of battery pack accessories .....	15
High voltage box accessory list .....	16
4.6 Installation of the Battery Module to the Rack .....	17
4.7 Battery cluster connected to inverter .....	19
4.8 System startup and shutdown .....	22
5. User Interface .....	23
5.1 Main Interface .....	23
5.2 Cell Voltage .....	23
5.3 Cell Temperature .....	24
5.4 Heating Temperature .....	24
5.5 Relay Status .....	25
5.6 Other .....	25
5.6.1 Heating Information .....	26
5.6.2 Insulation Resistense .....	26
5.6.3 Diagnostic Information .....	27
5.6.4 Cumulative Time Information .....	27
5.7 Set Up .....	28
6. Xiaodan Energy Storage App .....	29
6.1. App download .....	29
6.1.1 Android version .....	29

6.1.2 iOS version .....	29
6.2. Log in and register .....	30
6.2.1 Log in .....	30
6.2.2 Register .....	31
6.2.3 Experience login .....	32
6.3. Equipment distribution network .....	33
6.3.1 Overview .....	33
6.3.2 Distribution process .....	33
6.4. App page .....	38
6.4.1 Equipment .....	38
6.4.2 Data details .....	41
6.4.3 Mine .....	41
6.4.4 Message .....	46
6.4.5 App settings .....	57
7 Maintenance .....	49

# 1. Important information in the manual

## 1.1 Scope

The installation and operation manual applies to the modular battery energy storage system. Please carefully read this installation and operation manual to ensure the safe installation, preliminary debugging, and maintenance of battery . Installation, preliminary debugging, and maintenance must be carried out by qualified and authorized personnel. Please keep this installation and operation manual and other applicable documents near the battery energy storage system, so that all personnel involved in installation or maintenance can access this installation and operation manual at any time.

This installation and operation manual only applies to countries meeting the certification requirements. Please observe the applicable local laws, regulations, and standards. Standards and legal provisions of other countries may be inconsistent with the provisions and specifications in this manual. In this case, please contact our after-sales service personnel.

## 1.2 Description

Model	System energy(kwh)	Rated DC power(kw)	Discharge depth
48K-314	48.23	24.12	90%
64K-314	64.31	32.15	90%
80K-314	80.38	40.19	90%
96K-314	96.46	48.23	90%
112K-314	112.54	56.27	90%
128K-314	128.61	64.31	90%
144K-314	144.69	72.35	90%
160K-314	160.77	80.38	90%
176K-314	176.84	88.42	90%
192K-314	192.92	96.46	90%

## 1.3 Meaning of Symbols

This manual contains the following types of warnings:



**Danger!** It may cause an electric shock.

Even when the equipment is disconnected from the power grid, the voltage-free state will have a time lag.



**Danger!** If the instructions are not observed, death or severe injury may

occur.



**Warning!** If the instructions are not observed, a loss may occur.



**Attention!** This symbol represents information on the device use.

### Symbols on equipment:

The following types of warning, prohibition, and mandatory symbols are also used on the equipment.



**Attention!** The risk of chemical burns

If the battery is damaged or fails, it may lead to electrolyte leakage, which in turn causes the formation of a small amount of hydrofluoric acid, among other effects. Contact with these liquids can cause chemical burns.

- Do not subject the battery module to severe impact.
- Do not open, disassemble or mechanically change the battery module.
- In case of contact with an electrolyte, wash the affected area with clean water immediately and seek medical advice promptly.



### **Attention! The risk of explosion**

Incorrect operation or fire may cause the lithium-ion battery unit to ignite or explode, leading to serious injury.

- Do not install or operate the battery module in explosive or high-humidity areas.
- Store the battery module in a dry place within the temperature range specified in the data sheet.
- Do not open, drill through or drop the battery cell or module.
- Do not expose the battery cell or module to high temperatures.
- Do not throw the battery cell or module into the fire.
- If there is a fire from the battery, please use the CO2 extinguisher. If there is a fire near the battery, please use a dry powder extinguisher.
- Do not use defective or damaged battery modules.



### **Caution! Hot surface**

- If a malfunction occurs, the parts will become very hot, and touching them may cause serious injury.
- If the energy storage system is defective, please shut it down immediately.
- If the fault or defect becomes obvious, special care should be taken when handling the equipment.



**No open fire!** It is prohibited to handle open flames and ignition sources near the energy storage system.



Do not insert any objects into the opening in the housing of the energy storage system! No objects, such as screwdrivers, may be inserted through openings in the casing of the storage system.



**Wear safety goggles!** Wear safety goggles when working on the equipment.



**Follow the manual!** When working and operating the equipment, the

installation and operation manual provisions must be observed.

## 1.4 General Safety Information



**Danger!** Failure to comply with the safety information can lead to life-threatening situations.

1. Improper use can cause death. Operators of battery must read this manual and observe all safety information.
2. Operators of ML16K-HVR-07 must comply with the specifications in this manual.
3. This manual cannot describe all conceivable situations. For this reason, applicable standards and relevant occupational health and safety regulations are always given priority.
4. In addition, the installation may involve residual hazards in the following circumstances:
  - Incorrect installation.
  - The installation is carried out by personnel who did not receive relevant training or guidance.
  - Failure to observe the warnings and safety information in this manual.

## 1.5 Disclaimer

- Failure to comply with the provisions of this manual.
- Incorrect use of this product.
- Unauthorized or unqualified personnel repair the product, disassembly the rack and perform other operations.
- Use of unapproved spare parts.
- Unauthorized modifications or technical changes to the product.

## 1.6 Installation environment

- The battery energy storage system can only be installed and operated in an enclosed space. The working environment temperature range of battery is  $-20^{\circ}\text{C} \sim 55^{\circ}\text{C}$ , and the maximum humidity is 85%. The battery module shall not be exposed to the sun or placed directly beside the heat source.
- The battery module shall not be exposed to a corrosive environment.
- When installing the battery energy storage system, ensure that it stands on a sufficiently dry and flat surface with sufficient bearing capacity. Without the manufacturer's written approval,

the installation site's altitude shall not be higher than 2,000 meters. The output power of the battery decreases with the altitude.

- In areas where flooding may occur, care must be taken to ensure that the battery module is installed at a suitable height and to prevent its contact with water.
- The battery energy storage system must be installed in a fireproof room. This room must have no fire source and must be equipped with an independent fire alarm device, which complies with local applicable regulations and standards. According to local applicable regulations and standards, the room must be separated by the T60 fire door. Similar fire-proof requirements apply to other openings in the room (such as windows).

### Minimum product installation distance

The minimum distance to the surrounding building when the battery is installed is 10mm, and the minimum distance between the two products is 50mm.

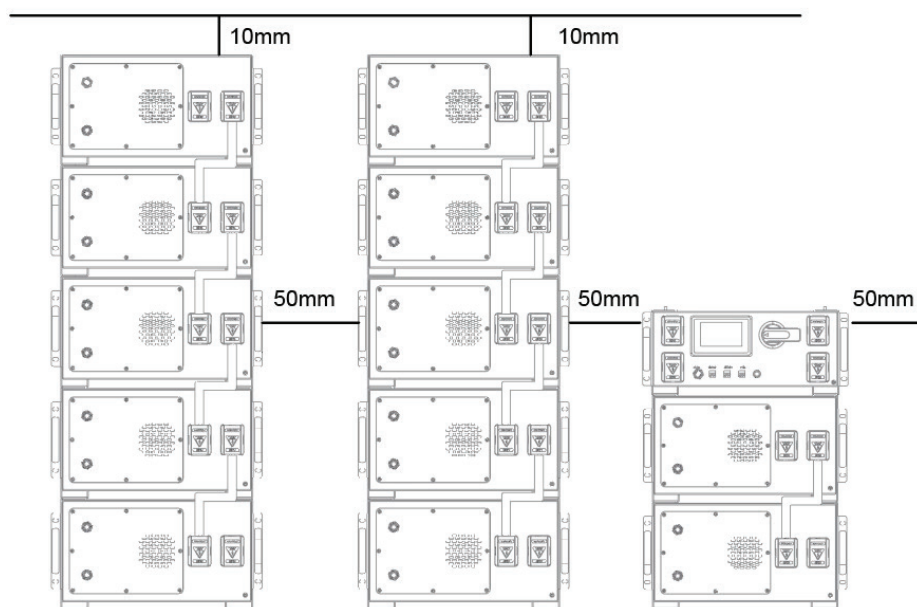

**Compliance with the specifications in this manual is also part of proper use.**

**The use of the system is prohibited in the following circumstances:**

- Mobile use on land or in the air (use on water only with the manufacturer's consent and with the manufacturer's written consent).
- Used in medical devices.
- Used as a UPS system.

## 1.7 Requirements for Installation Personnel

All work shall comply with local applicable regulations and standards.

The installation can only be completed by electricians with the following qualifications:

- Trained in dealing with hazards and risks associated with the installation and operation of electrical equipment, systems, and batteries.
- Trained on installation and debugging of electrical equipment.
- Understanding and complying with the technical connection conditions, standards, guidelines, regulations, and laws applicable.
- Knowledge of handling lithium-ion batteries (transportation, storage, disposal, hazard source).
- Understanding and complying with this document and other applicable documents.

## 2. Safety

### 2.1 Safety rules

To avoid property damage and personal injury, the following rules shall be followed when working on the hazardous live parts of the battery energy storage system:

- It is available for use.
- Ensure that it will not restart.
- Make sure there is no voltage.
- Grounding protection and short circuit protection
- Cover or shield adjacent live parts.

### 2.2 Safety information

Part damage or short circuit may cause electric shock and death. A short circuit can be caused by connecting battery terminals, resulting in current flow. This type of short circuit shall be avoided under any circumstances. For this reason, follow these instructions:

- Use insulated tools and gloves.
- Do not put any tools or metal parts on the battery module or high-voltage BMS box.
- When operating the battery, be sure to remove watches, rings, and other metal objects.
- Do not install or operate this system in explosive or high-humidity areas.
- When working on the energy storage system, first turn off the charging controller, then the battery, and ensure that they are not turned on again.

**Improper use of the battery energy storage system can lead to death.** The use of the battery energy storage system beyond its intended use is not allowed, because it may cause great danger.

**Improper handling of the battery energy storage system can cause life-threatening risks, serious injury or even death.**



Warning! Improper use can cause damage to the battery cell.

- Do not expose the battery module to rain or soak it in liquid.
- Do not expose the battery module to a corrosive environment (such as ammonia and salt).
- The battery energy storage system shall be debugged no later than six months after delivery.

## 3. Transport to the end customers

### 3.1 Provisions on Shipping of Battery Modules:

It is necessary to comply with the relevant regulations and provisions on roads for shipping lithium-ion products in the corresponding countries.



It is prohibited to smoke in the vehicle during transportation or in the vicinity during loading and unloading.



The dangerous goods transport vehicles shall meet relevant regulations concerning road transportation and shall be equipped with two tested CO<sub>2</sub> fire extinguishers.



It is forbidden for the freight forwarder to open the outer package of the battery module. Use only approved lifting equipment to move the battery cabinet system. Use only the hanging lug on the top of the battery cabinet as the connection point. When lifting, the angle of the sling must be at least 60°.





Improper vehicle transportation can cause injury. Improper transportation or improper transportation locks may cause the load to slip or overturn, resulting in injury. The cabinet shall be placed vertically to prevent it from sliding in the vehicle, and a fixing belt shall be used.





A tilting of the battery rack may cause injury. The maximum weight of a single battery rack can reach 640 kg. When tilted, they may overturn, causing injury and damage.

Ensure that the battery cabinet is on a stable surface and that it does not tilt due to load or force.

 The battery energy storage system can be damaged, if not properly transported. The battery module can only be transported vertically. Note that these parts may be top-heavy. Failure to follow this instruction may result in damage to the part.

 During transportation, the battery storage rack may be damaged when it is installed with the battery module. The battery storage rack is not designed to be transported with the installed battery modules. Always transport the battery module and the battery rack separately. Once the battery module is installed, do not move the battery rack, and do not lift it by a lifting device.

 If possible, do not remove the transport packaging before arrival at the installation site. Before removing the transport protector, check if the transport packaging is damaged, and check the impact indicator on the outer packaging of the battery converter. If the impact indicator is triggered, the possibility of transport damage cannot be ruled out.

 Improper transportation of battery modules may cause injury. The single battery module weighs 44 kg. If it falls or slips, it may cause injury. Only use suitable transport and lifting equipment to ensure safe transport.

 Wear safety shoes to avoid the danger of injury. When transporting the battery rack and battery module, their parts may be crushed due to their heavy weight. Therefore, all persons involved in transportation must wear safety shoes with toe caps. Please observe the safety regulations for transportation at the end customer's site, especially during loading and unloading.

 During transportation and installation of unpacked battery storage cabinets, the risk of injury increases, especially on sharp metal panels. Therefore, all personnel involved in transportation and installation must wear protective gloves.

 The maximum weight of a single rack can reach 640kg. We suggest that at least 2-3 people work together to install the battery rack. The lifting device is helpful for heavy parts, and the pulley or cart for light parts. Be careful not to damage the case. The number of battery modules stacked shall not be more than 8.

**Check whether the delivery is complete.**

## **3.2 Permissible and Impermissible Storage Positions of a Packaged Battery Module**

The battery module can only be transported in an upright position. Please note that the battery rack may be very top-heavy.

## 4. Description and installation of ML16K-HVR-07 battery

### 4.1 Installation Precautions



**WARNING! Possible damage to the building due to static overload**

1. The total weight of the battery storage system is kgs. Ensure that the installation site has sufficient bearing capacity.
2. When selecting the installation site, consider the transportation route and necessary site cleanup.

### 4.2 ML16K-HVR-07 Product Description

ML16K-HVR-07 is a high-voltage lithium-ion battery system. It provides a reliable backup power supply for supermarkets, banks, schools, farms and small factories to smooth the load curve and achieve peak load transfer. It can also improve the stability of renewable systems and promote the application of renewable energy.

It is characterized by high integration, good reliability, long service life, wide working temperature range, etc. The battery energy storage system is modular. Each battery module has a capacity of 16.07 kWh. It can support up to 12 battery modules in series. Its total energy can be expanded from 48.23 kWh to 192.92 kWh.

### 4.3 Technical Data

Technical specification	48KWH	64KWH	80KWH	96KWH	112KWH	128KWH	144KWH	160KWH	176KWH	192KWH
Installation Mode	Racked									
Battery Type	LifePO4(LFP)									
Module Energy (kWh)	16									
Module Nominal Voltage (V)	51.2									
Module Capacity (Ah)	314									

Battery Module Qty InSeries (Optional)	3	4	5	6	7	8	9	10	11	12
System Nominal Voltage (V)	153.6	204.8	256.0	307.2	358.4	409.6	460.8	512.0	563.2	614.4
System Operating Voltage (V)	139.2~ 170.4	185.6~ 227.2	232.0~ 284.0	278.4~ 340.8	324.8~ 397.6	371.2~ 454.4	417.6~ 511.2	464.0~ 568.0	510.4~ 624.8	556.8~ 681.6
System Nominal Capacity (KWh)	48.23	64.31	80.38	96.46	112.54	128.61	144.69	160.77	176.84	192.92
Usable Capacity (KWh)	43.41	57.88	72.35	86.81	101.28	115.75	130.22	144.69	159.16	173.63
Weight (Kg)	391	513	635	757	879	1001	1123	1245	1367	1489
Recommend Charge/Discharge Current (A)	150									
Communication	CAN									
Ingress Protection	IP20									
Altitude	≤2000m									
Cycle Life	25±2°C,0.5C/0.5C,EOL70%≥8000									
Monitoring Parameters	System voltage,Current,cell voltage,cell temperature,module temperature									
SOC	Intelligent algorithm									
Working Temperature	0°C~45°C Charge    -10°C ~55°C Discharge									
Storage Temperature	0~35°C									

## 4.4 Description of Battery Module

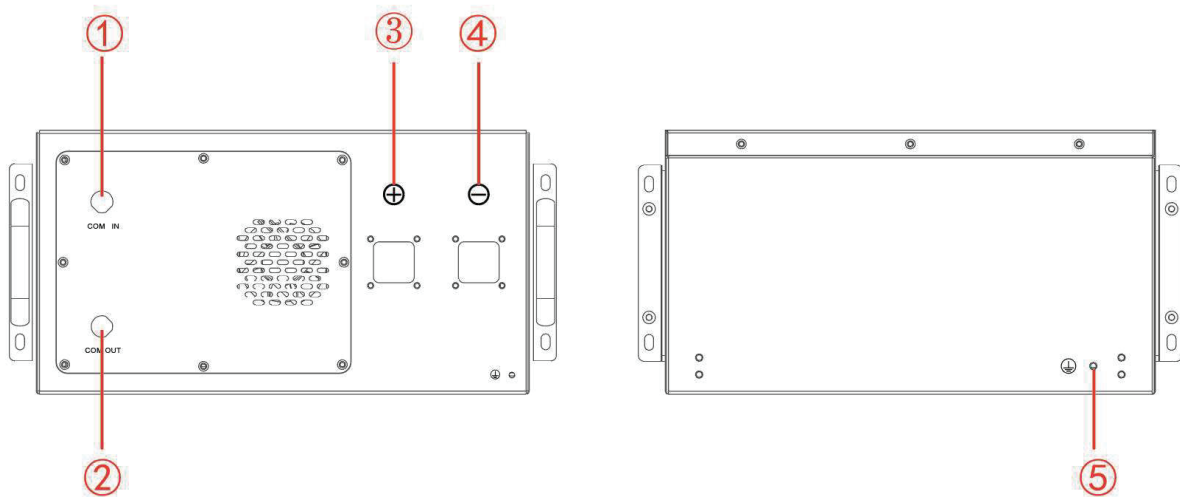

NO.	Name	Description.	Position
1	COM IN	Connection position of battery module communication supply input or output. Definition: 1:P-IN、 2:IM-IN、 3:FAN+、 4:FAN+、 5:FAN-、 6:FAN-	Front
2	COM OUT	Connection position of battery module communication and power supply input or output. Definition: 1:IP-OUT、 2:IM-OUT、 3:FAN+、 4:FAN+、 5:FAN-、 6:FAN-	Front
3	B+	Battery module positive pole (orange)	Front
4	B-	Battery module negative pole (black).	Front
5	Earthing wire	Battery module grounding location	behind



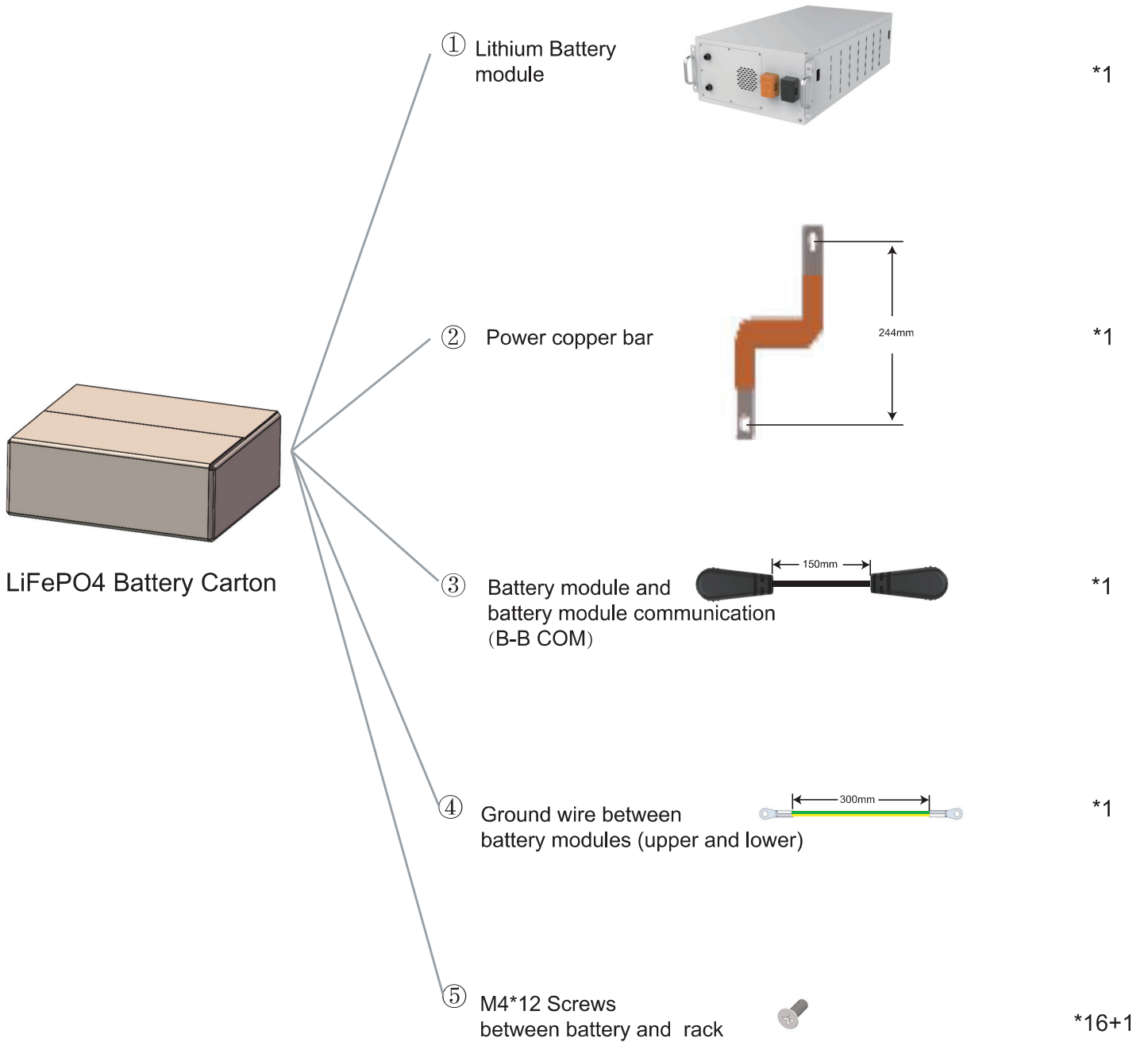



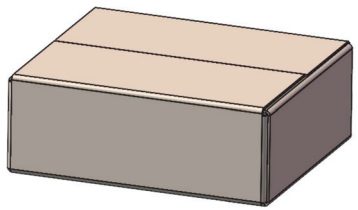

# List of battery pack accessories

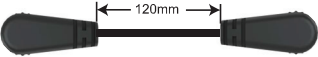
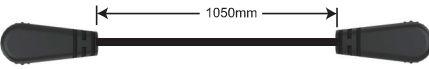

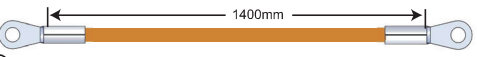
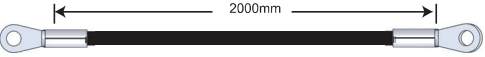
# High voltage box accessory list



High voltage box Carton

- ① High Voltage BMS box  \*1
- ② Communication between battery module and high-voltage box (B-HV COM)  \*1
- ③ Communication between battery racks and battery packs (B-B COM)  \*2
- ④ Positive power cable between battery module and BMS box  \*1
- ⑤ Negative power cable between battery module and BMS box  \*1
- ⑥  \*2
- ⑦ Negative power cable between BMS box and Inverter  \*1
- ⑧ Positive power cable between BMS box and Inverter  \*1
- ⑨ Communication cable between BMS box and Inverter  \*1
- ⑩ Ground wire between battery modules (left and right)  \*2
- ⑪ Ground wire between high voltage box and grounding copper busbar  \*1
- ⑫ M4\*12 Screws between battery and rack  \*8+1

## 4.5 Description of high-voltage BMS box

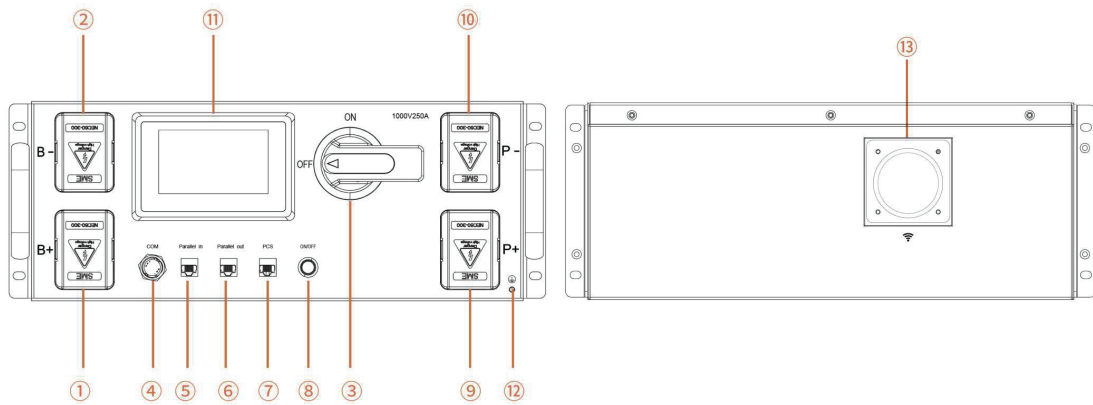

NO.	Name	Description.	Position
①	B+	High voltage box module positive pole (orange)	Front
②	B-	High voltage box module negative pole (black).	Front
③	Air switch	Used to manually control the connection between the battery rack and external devices.	Front
④	COM	Communication port between battery and high-voltage box Definition: 1:ISOPSPI_H, 2:ISOPSPI_L, 3:FAN+, 4:FAN+, 5:FAN-, 6:FAN-	Front
⑤	Parallel in	Parallel communication input port Definition: 1:GND, 2:GND, 3:CAN1G, 4:CAN1H, 5:CAN1L, 6:DIG_IN2	Front
⑥	Parallel out	Parallel communication output port Definition: 1:GND, 2:GND, 3:CAN1G, 4:CAN1H, 5:CAN1L, 6:HSS1	Front
⑦	PCS	Inverter communication port Definition: 1:RS485A_1, 2:RS485B_1, 3:CAN1G, 4:CAN1H, 5:CAN1L, 6:RS485G_0, 7:DEBUG CANH, 8:DEBUG CANL	Front
⑧	ON/OFF	BMS start button and Green indicator light	Front
⑨	P+	Connect the high-voltage box to the positive pole of the inverter	Front
⑩	P-	Connect the high-voltage box to the negative pole of the inverter	Front
⑪	Human-machine interface (HMI)	Display some important battery information.	Front
⑫	Earthing wire	Battery module grounding location	Front
⑬	WiFi	High voltage box WiFi signal antenna	Rear

## 4.6 Installation of the Battery Module to the Rack



Insufficient or no grounding may cause an electric shock. Device malfunctions, and insufficient or no grounding may cause device damage and life-threatening electric shocks.



Note: Before installing the battery, please turn the manual switch of the high-voltage control box to the off position.



### CAUTION

Remember that this battery is heavy! Please be careful when lifting out from the package.



### CAUTION

**Note the allowable installation modes :**

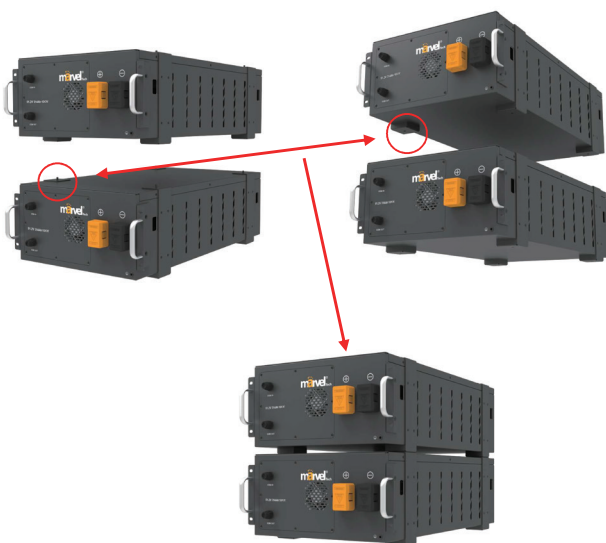

NOTE : Align the protrusions with the holes and snap them together.

① Install the lug on the battery module and high-voltage BMS box.

② Insert the first battery module into the battery module rack located at the bottom cluster rack; Then continue the installation in the same way from bottom to top until reaching the 5th floor. If it exceeds the 5th floor, a new column should be stacked and inserted into the high-voltage BMS box at the top of the last battery pack.

③ After the battery module and control box is inserted into the rack, use M4\* 12 outer hexagon cross combination screws to fix all the lugs of the battery module and control box on the side beam in turn.

④ Connect bronze, cable, communication harness in turn, and fix.

Note: The stacking of single-cell battery packs is prohibited beyond five units

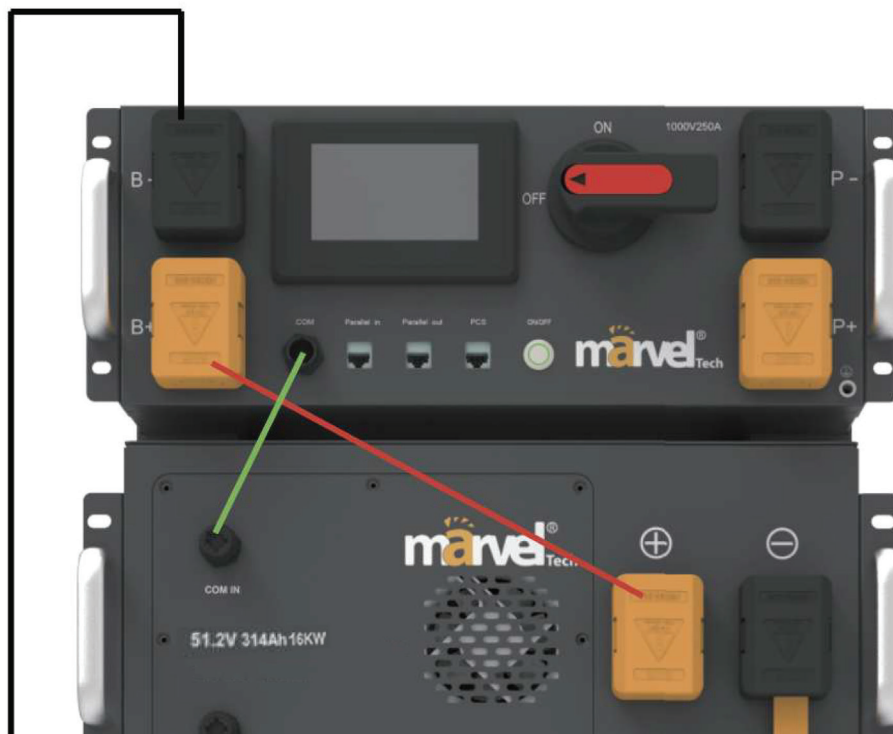

### 4.7 Battery cluster connected to inverter

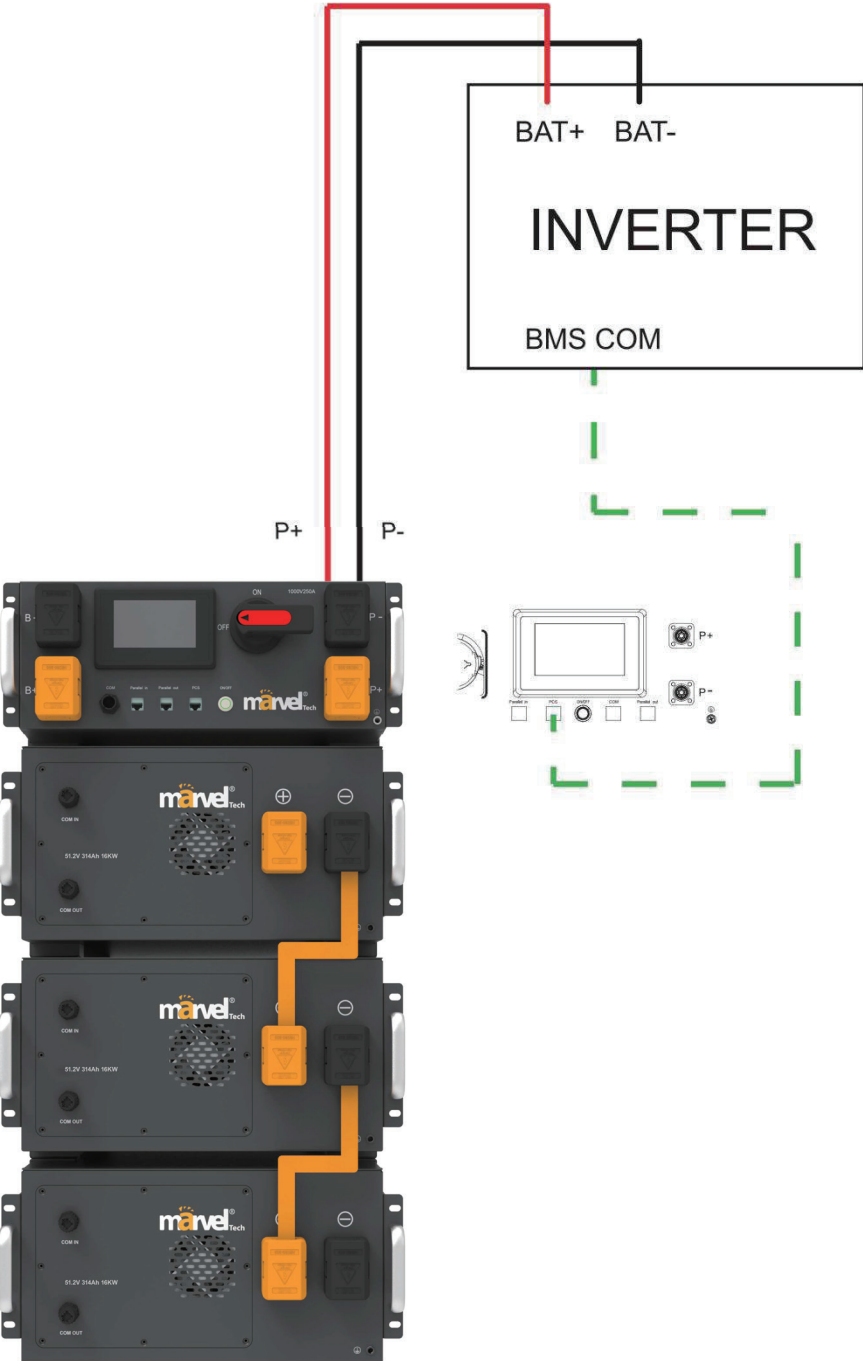

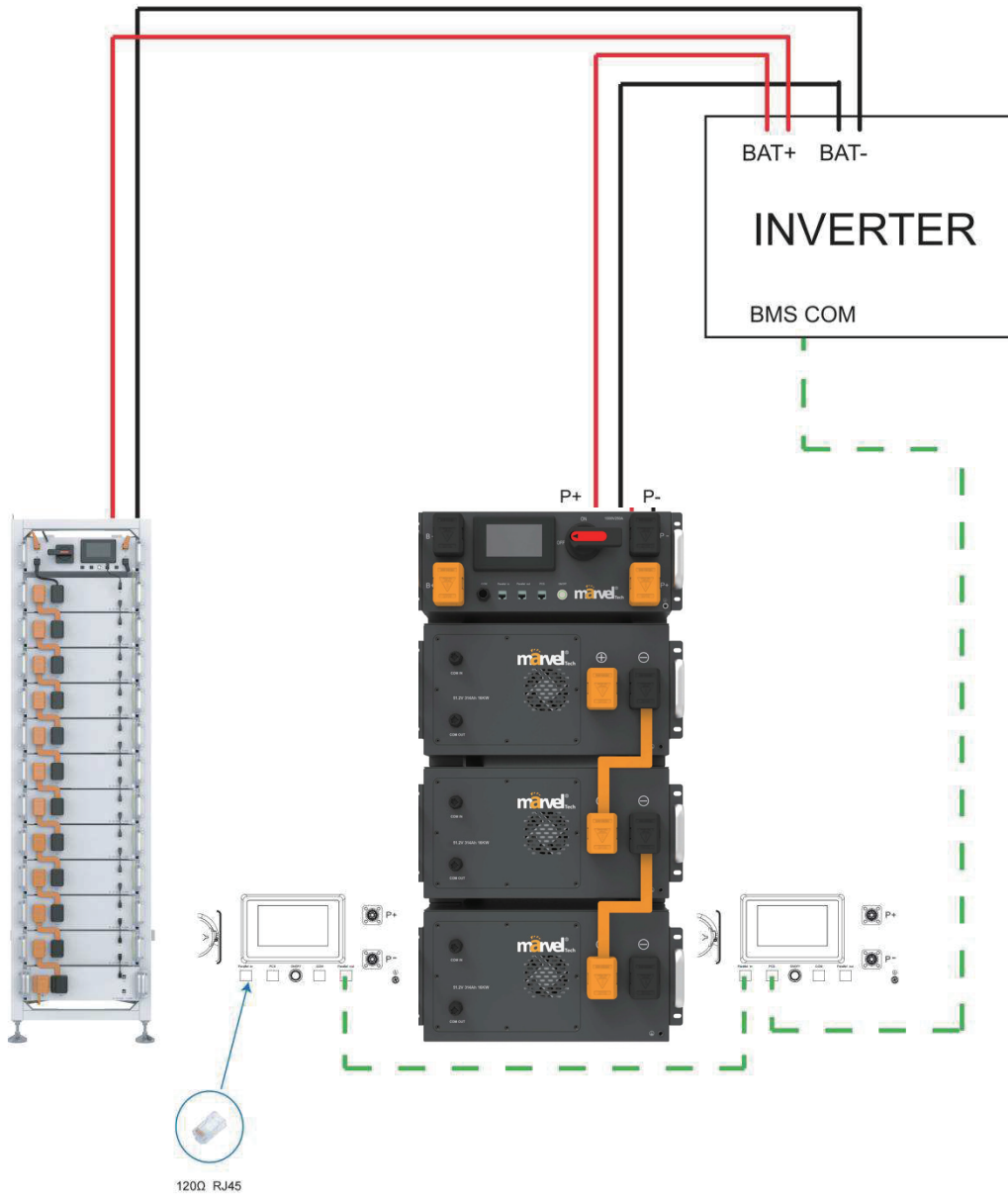

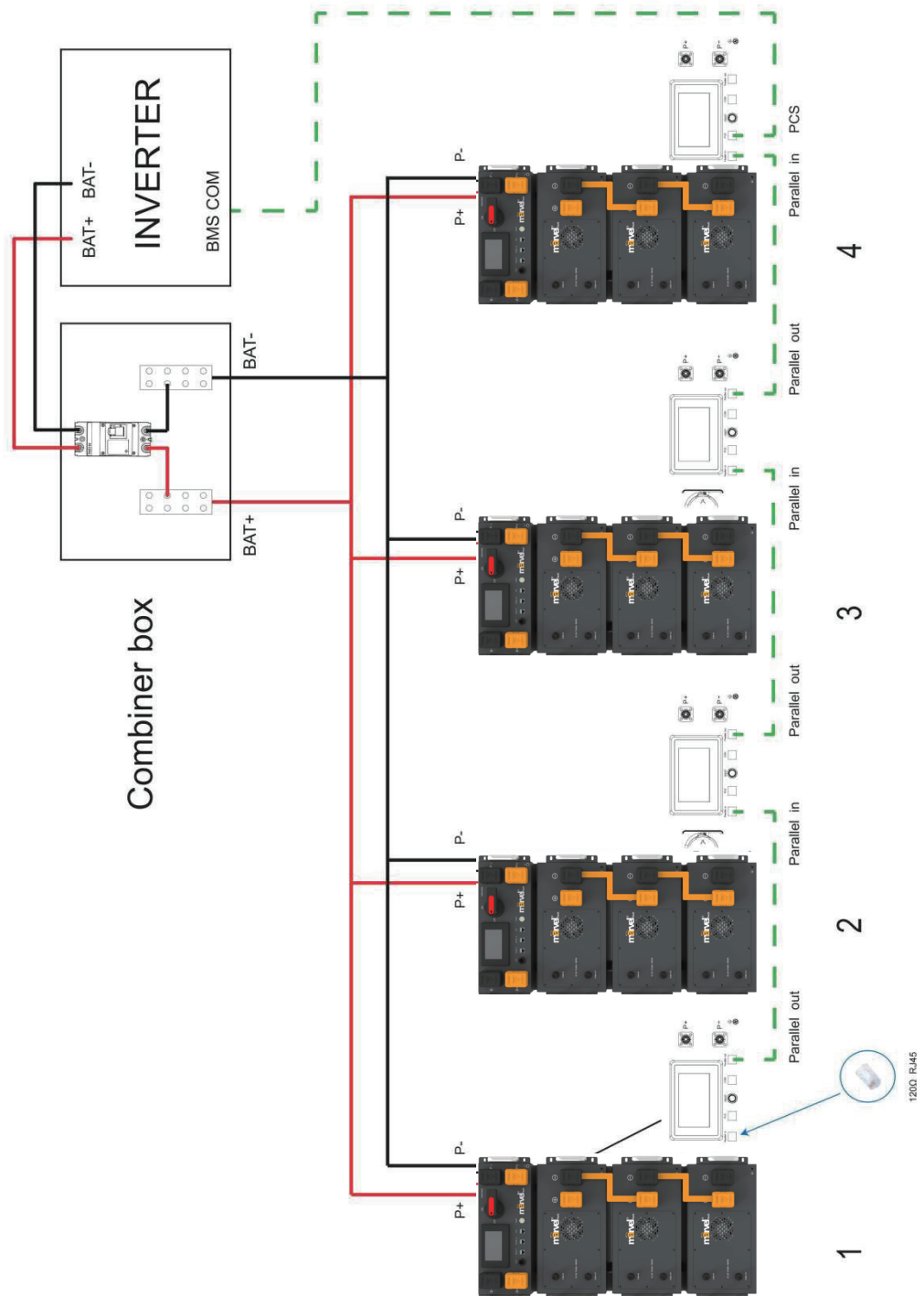

## 4.8 System startup and shutdown

### Startup procedure

- ① After connecting the battery cables, press the DC circuit breaker on the high-voltage BMS box to turn OFF to ON.
- ② Press the start button and wait for the screen to light up.
- ③ Turn on the circuit breaker after the battery pack is started.
- ④ Complete boot.

### Shutdown procedure

- ① Press the start button again and wait for the screen to go off.
- ② Press the DC circuit breaker ON the high pressure control box and set the "ON" to the "OFF" position.
- ③ Turn off the circuit breaker after the battery pack is closed.
- ④ Complete shutdown.

Description of external circuit breakers between inverter and battery system

## 5 User Interface

### 5.1 Main Interface



### 5.2 Cell Voltage



### 5.3 Cell Temperature

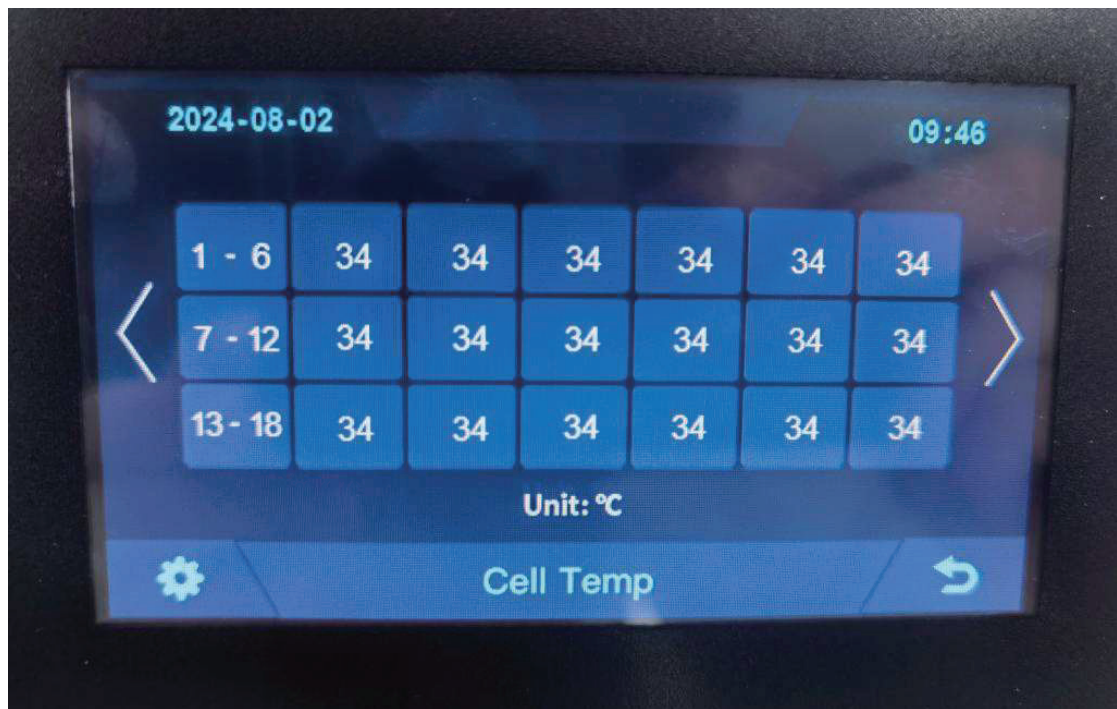

### 5.4 Heating Temperature



## 5.5 Relay Status

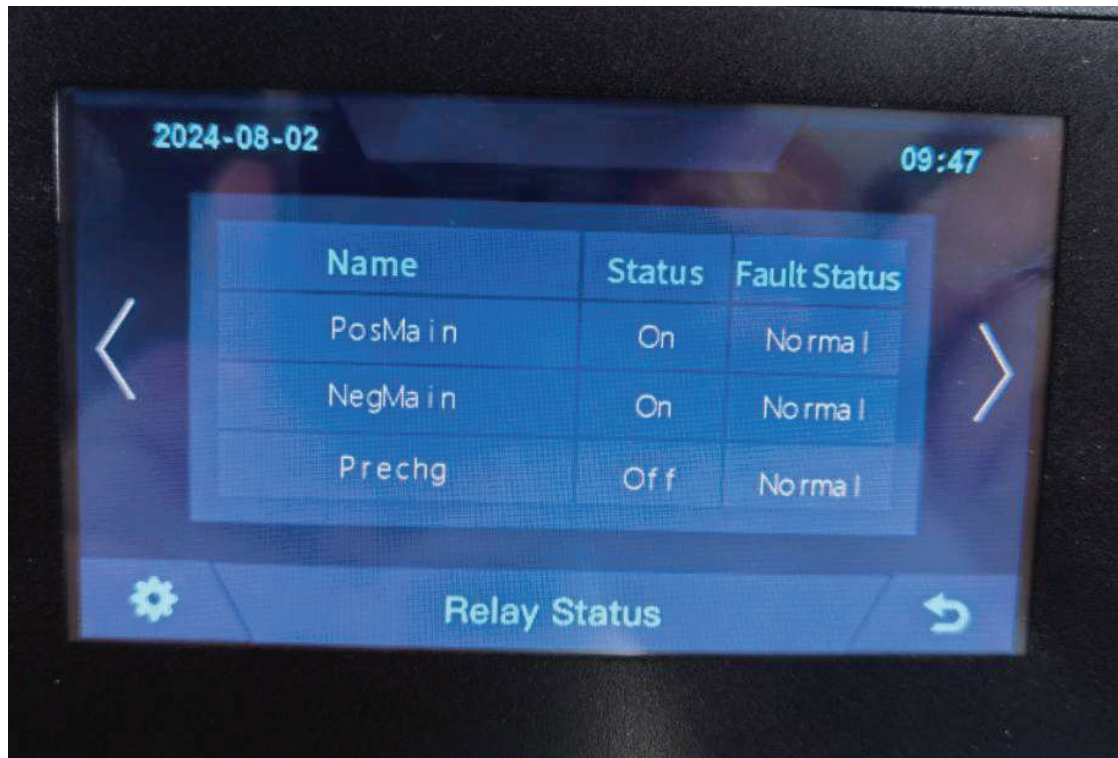

## 5.6 Other

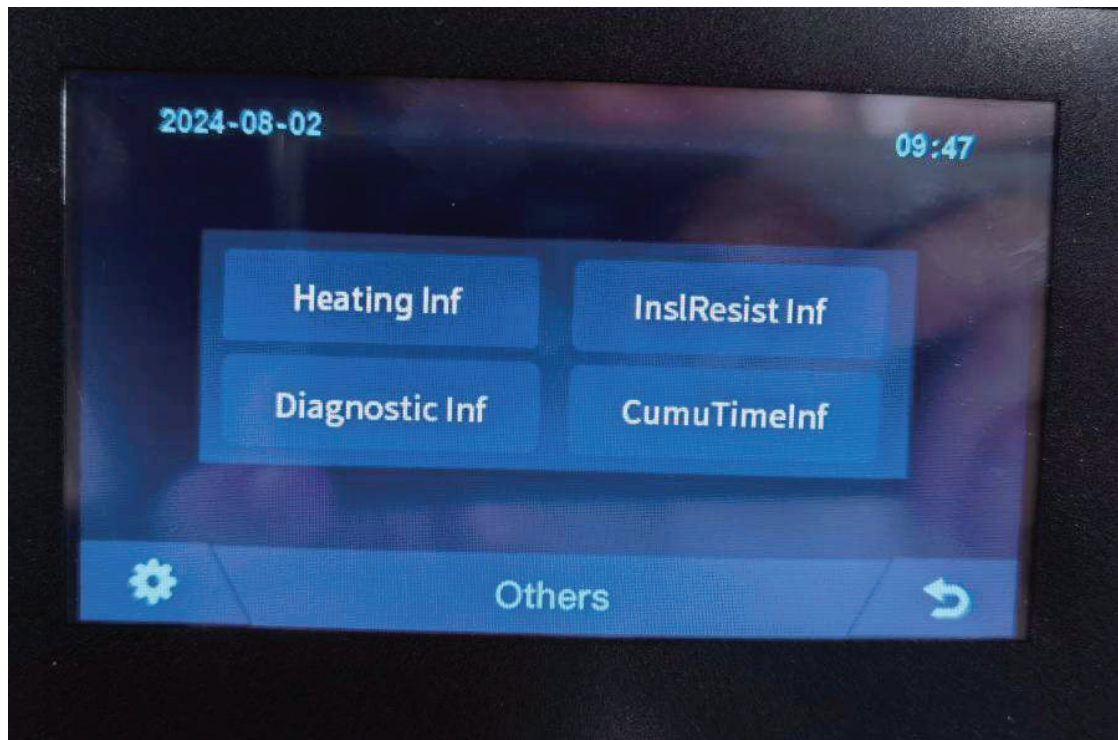

### 5.6.1 Heating Information



### 5.6.2 Insulation Resistense



### 5.6.3 Diagnostic Information



### 5.6.4 Cumulative Time Information

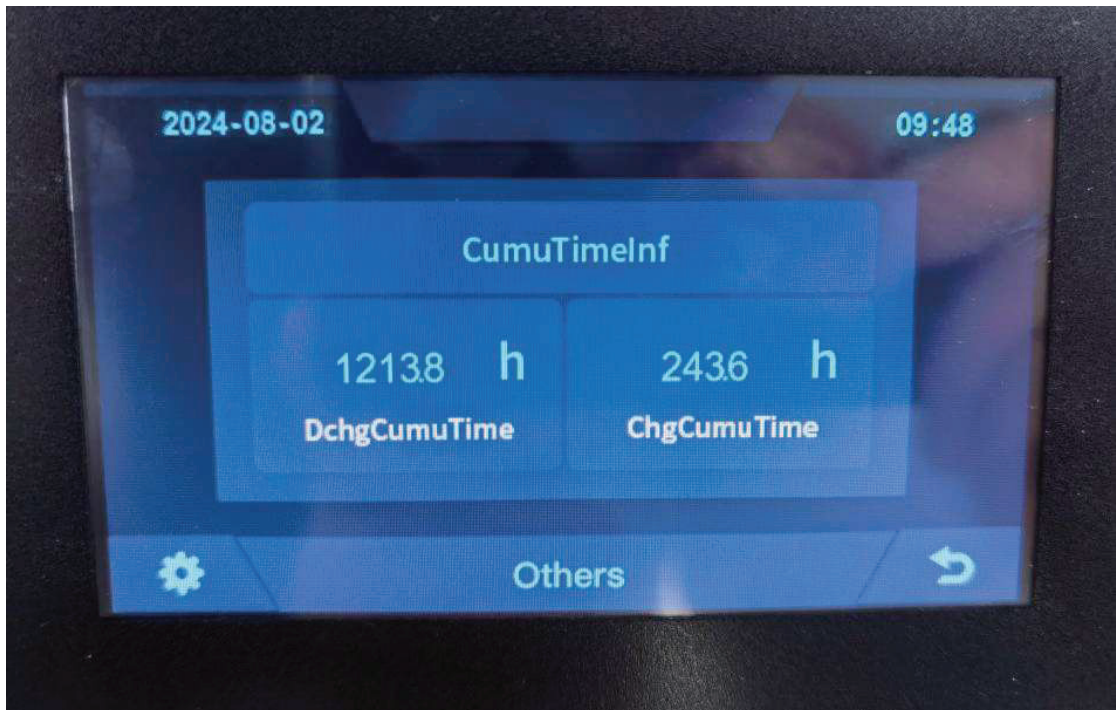

## 5.7 Set Up



## 6 Xiaodan Energy Storage App

### 6.1. App download

#### 6.1.1 Android version

1. Enter the official website of Youdan Technology <https://www.udantech.com/#/> , click on the "SAAS Application" column in the top navigation bar, pull down to the mobile app application module, and you can see the mobile WeChat Mini Program and App application download.

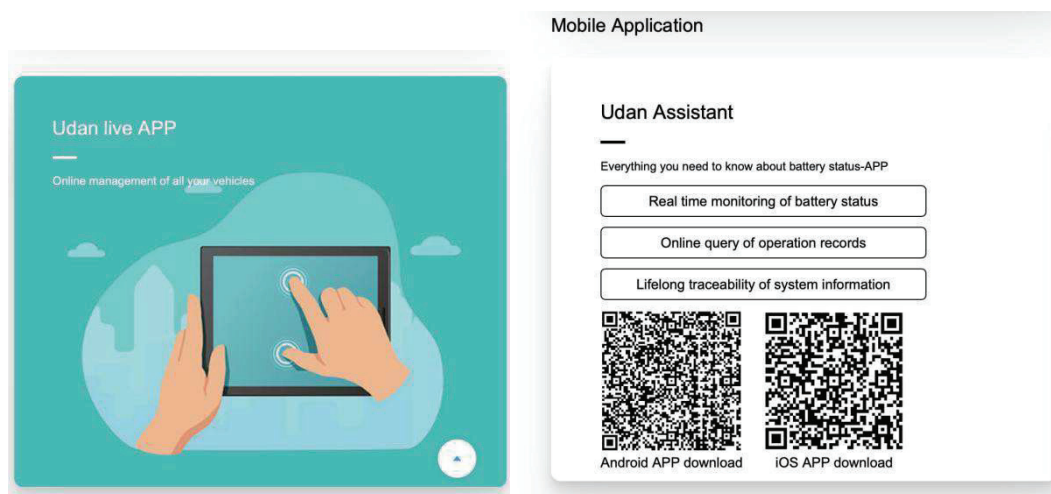
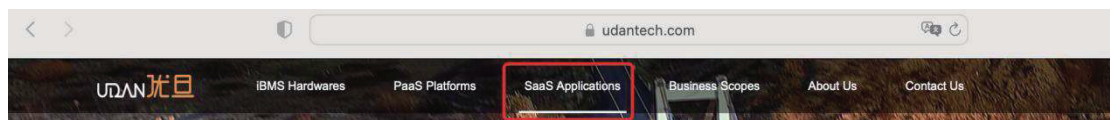

#### 6.1.2 iOS version

Enter the mobile App Store, search for " Udan HESS ", and you can download and install it.

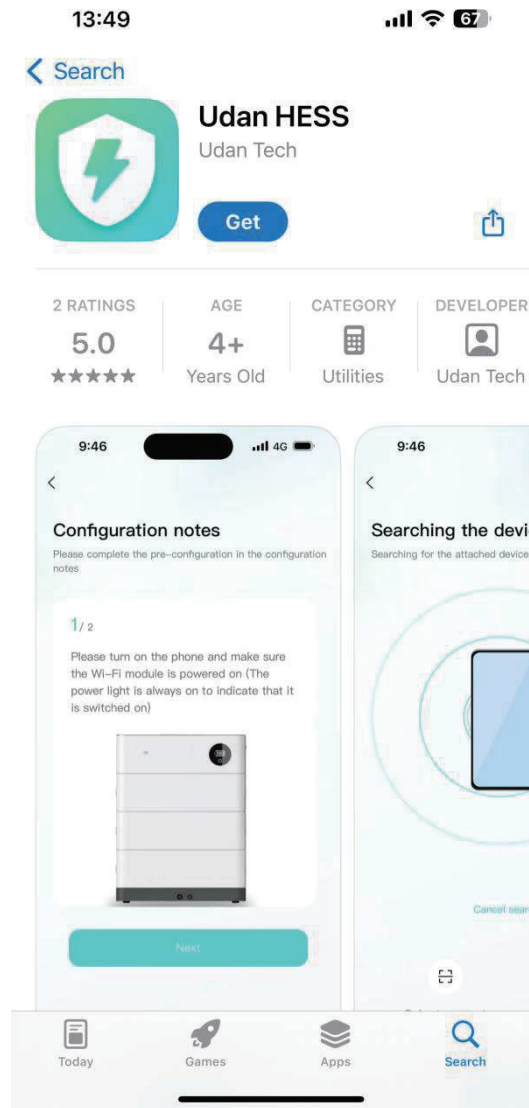
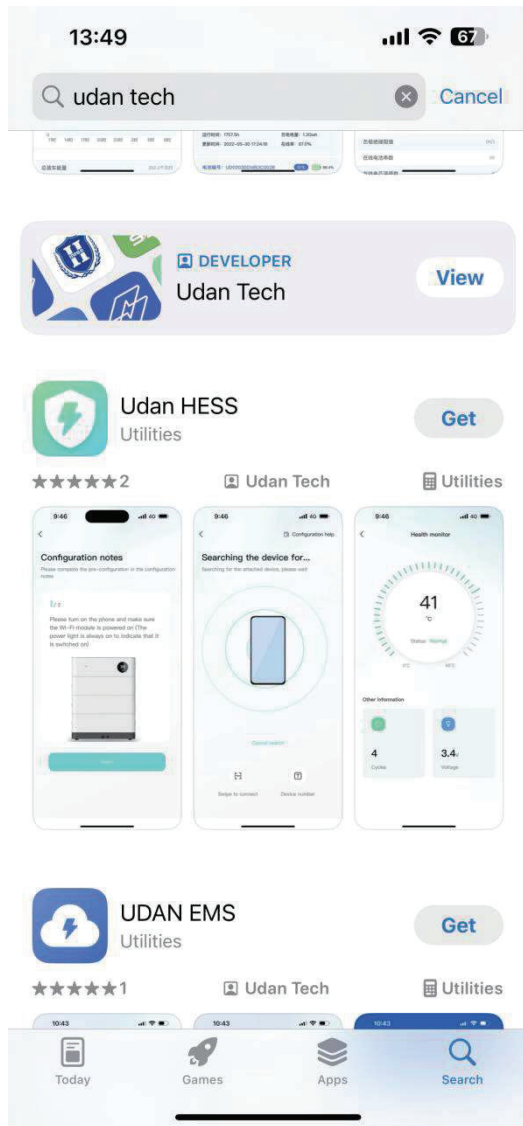

## 6.2. Log in and register

### 6.2.1 Log in

- After opening the APP, enter the login interface to log in with your account.
- Currently supports logging in through email accounts

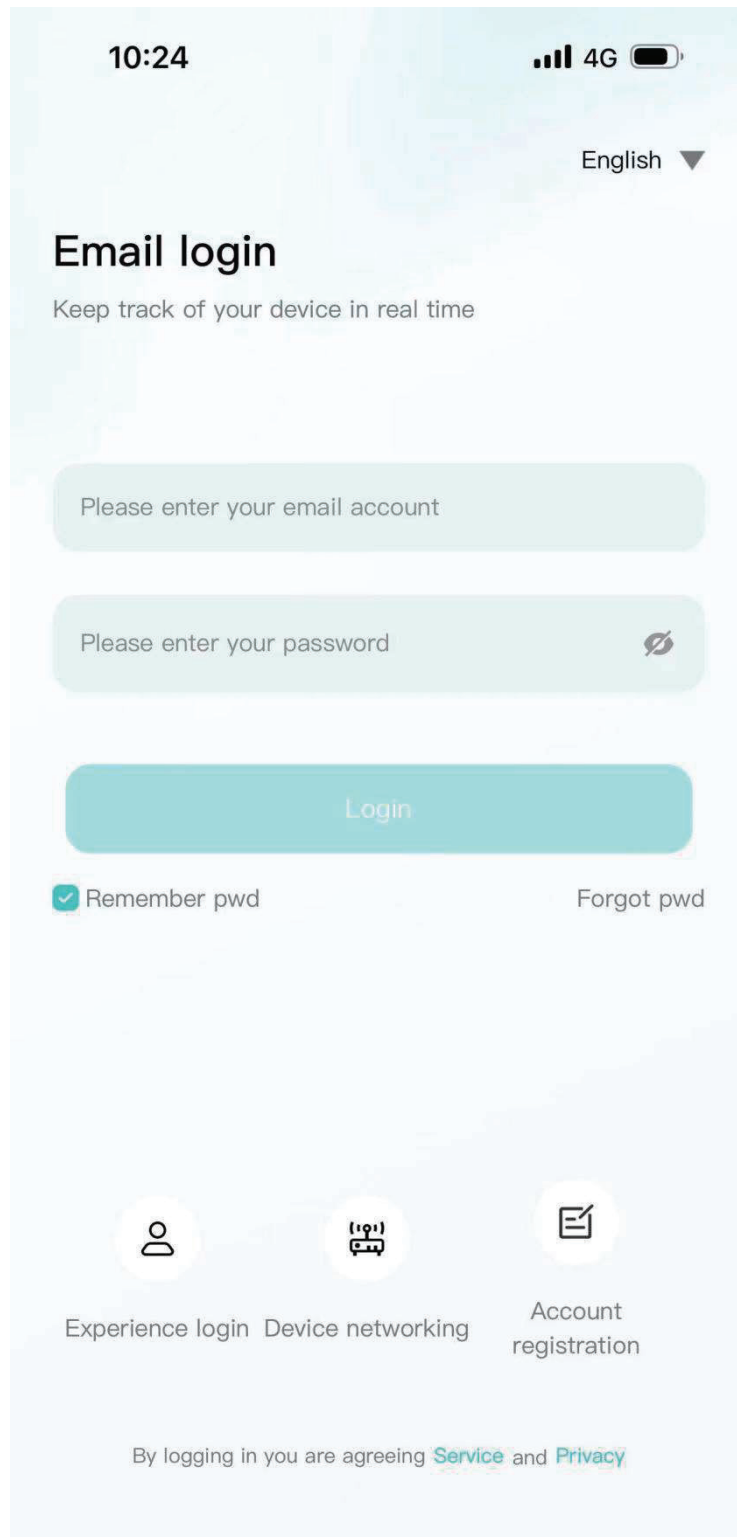

## 6.2.2 Register

- At the bottom of the login page, click the "Account Registration" button to enter the registration process.

- Currently, you can register with an email account. After registration, you need to go through the device verification process and enter the device SN code or device QR code for identification.

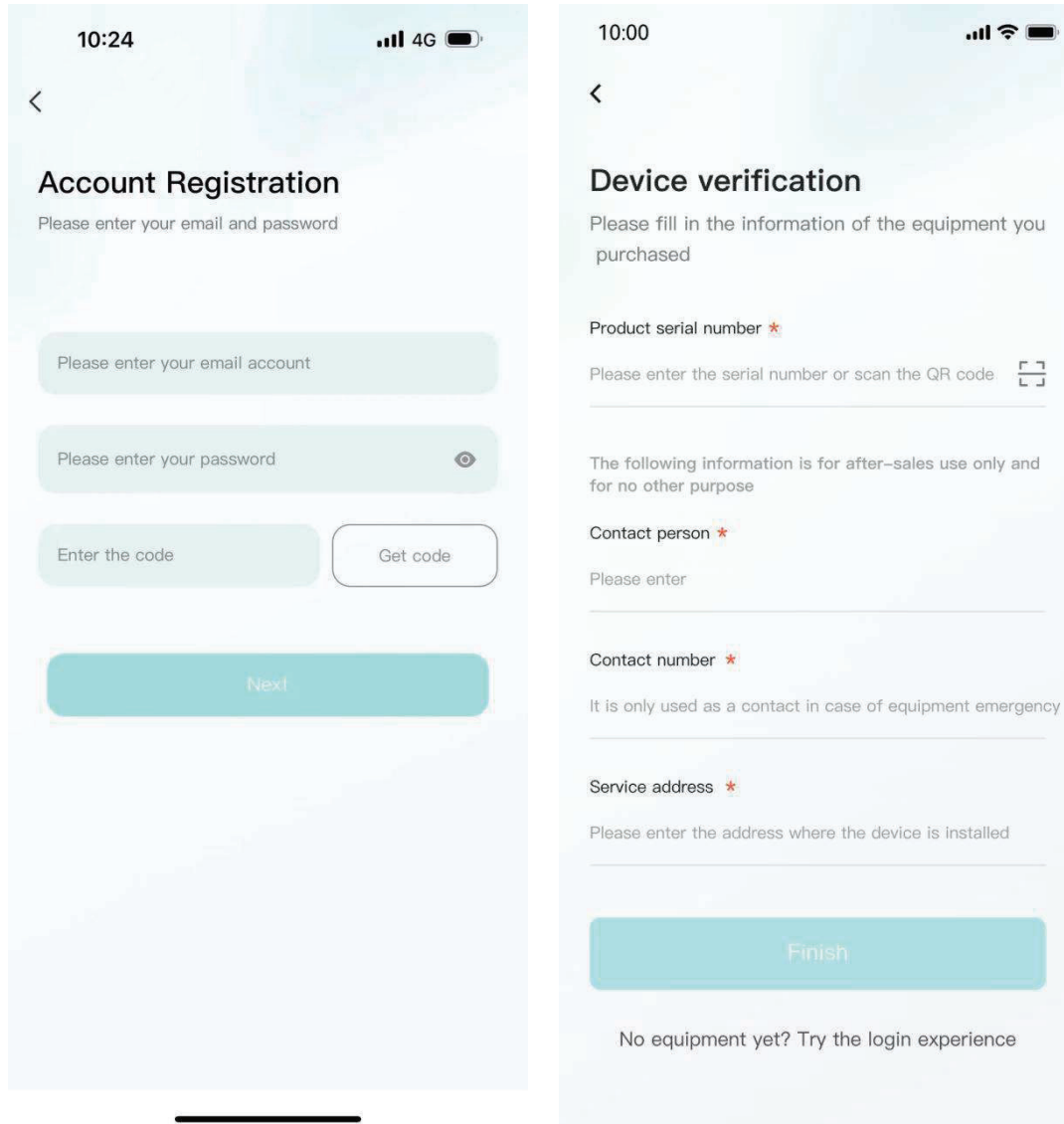

### 6.2.3 Experience login

- At the bottom of the login page, click the "Experience Login" button to experience the app function without registration as a tourist.

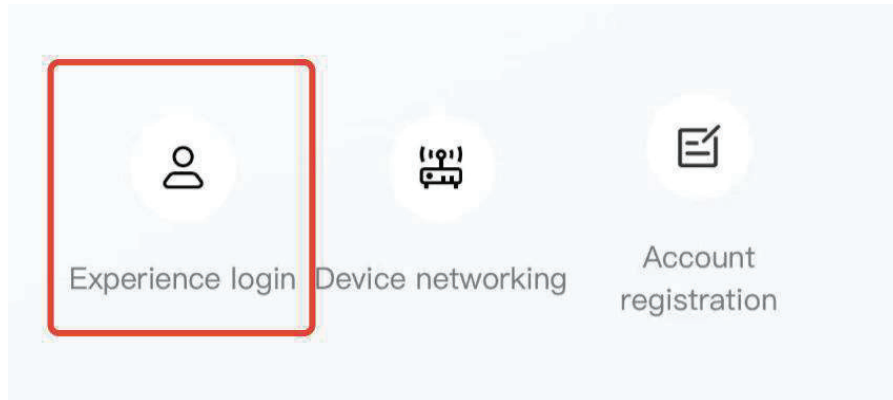

## 6.3. Equipment distribution network

### 6.3.1 Overview

Device distribution network refers to connecting devices to the Cloud Computing Platform to help users obtain real-time device data information.

### 6.3.2 Distribution process

1. Preparation before distribution: Ensure that the **device is on** , turn on the **mobile phone Bluetooth and wireless LAN** functions.

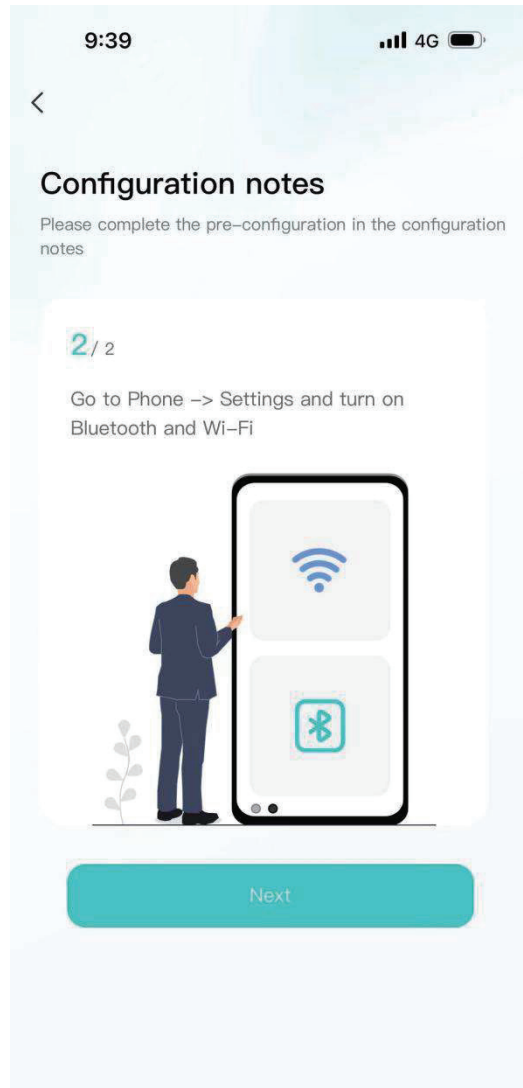

2. Connected devices: The current App supports **Bluetooth search, device scanning, and manual input of SN code** .

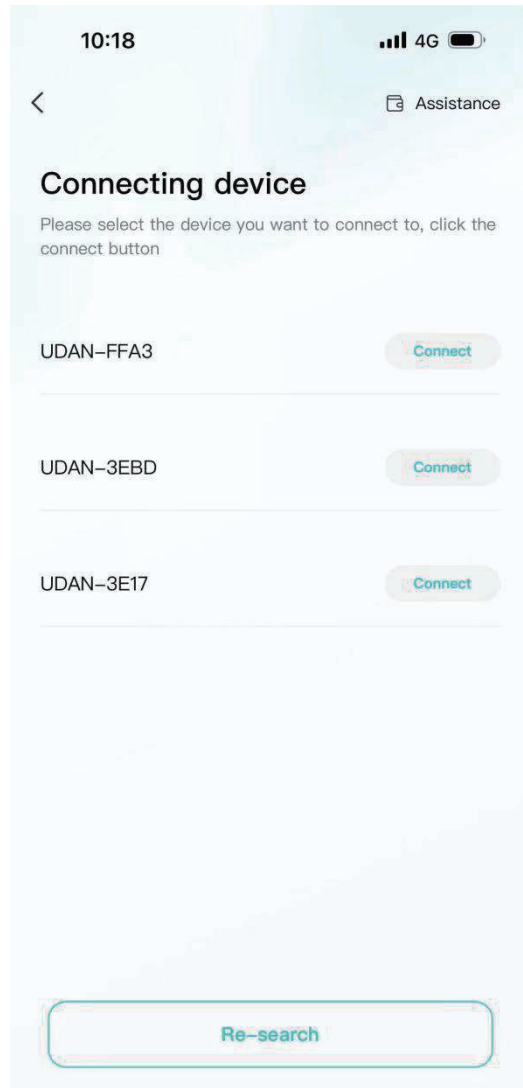
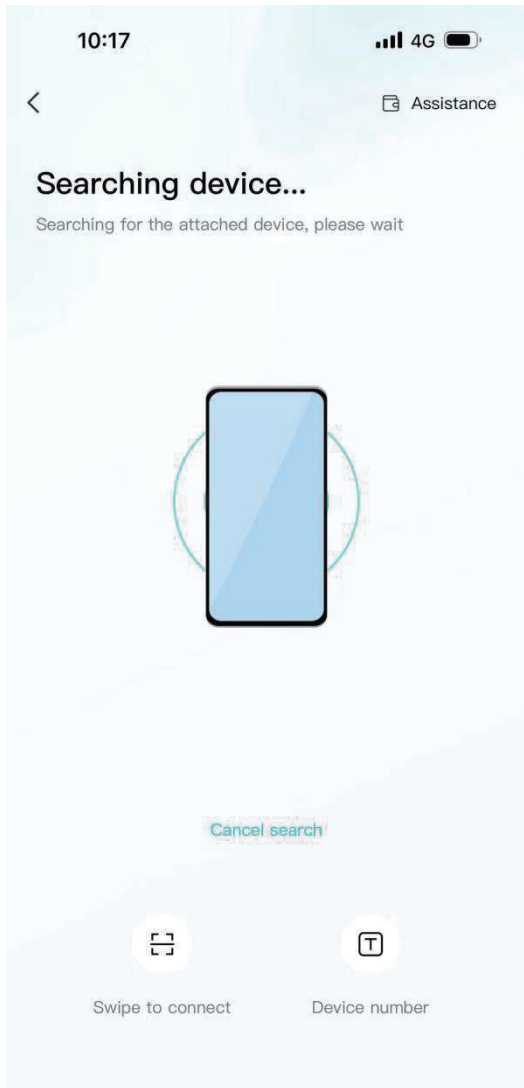

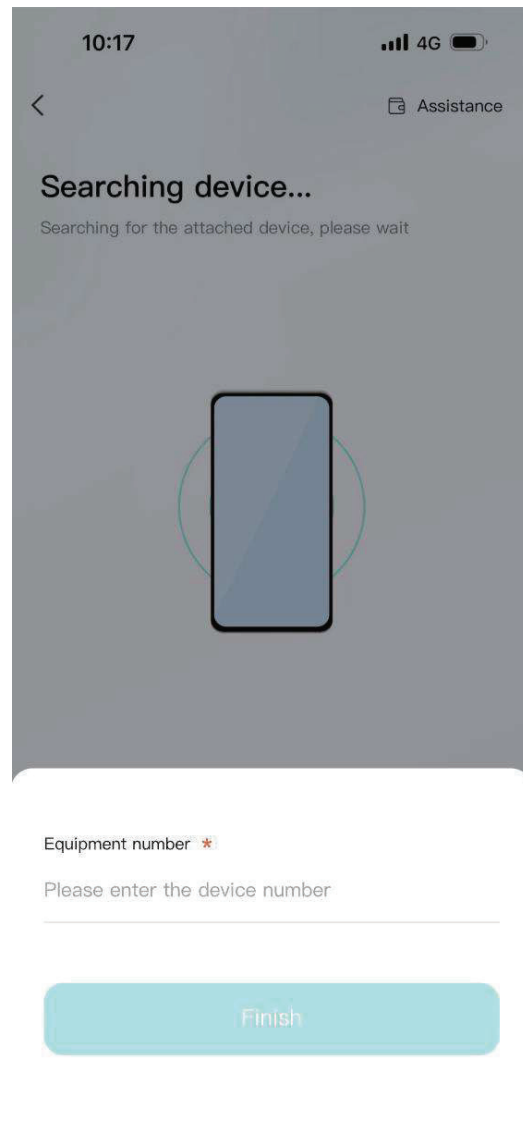
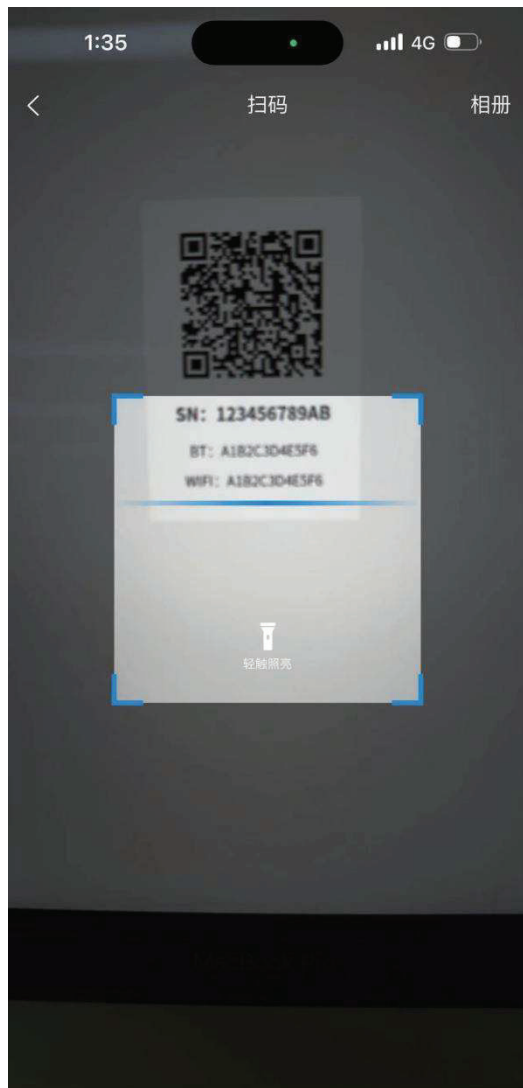

3. Connect to WiFi: After the device is connected, enter the WiFi connection process.

- Select the WiFi you want to use and click the "Connect" button. Enter the WiFi password and click the "Finish" button to distribute the network.

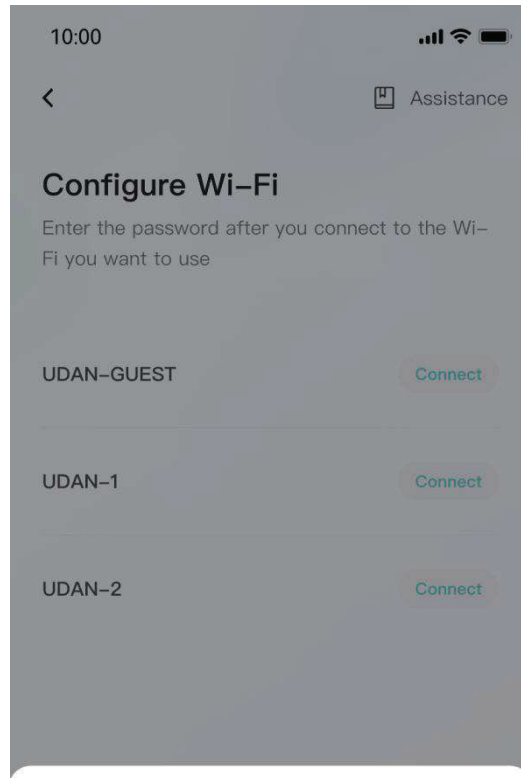
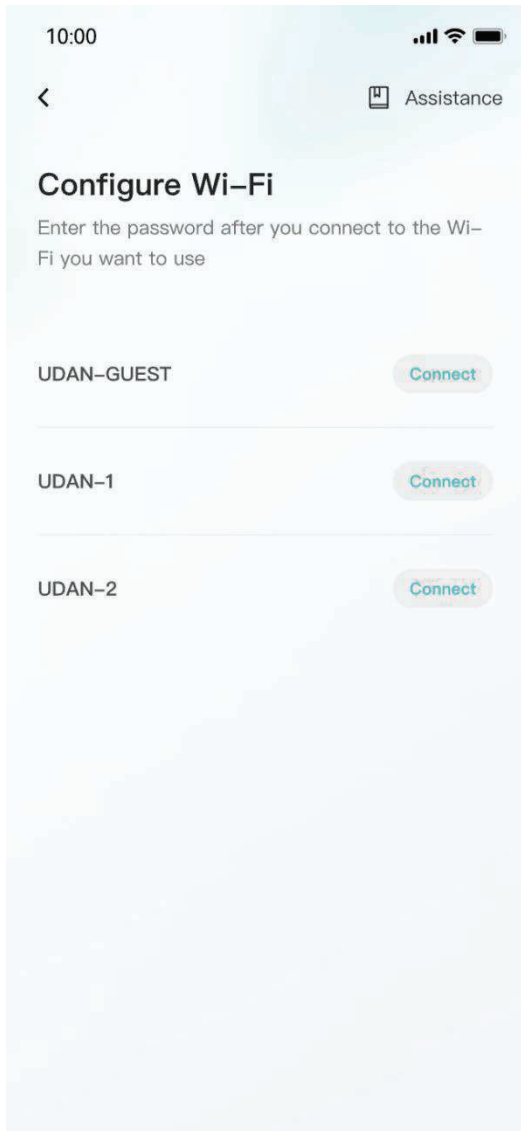

Wi-Fi Password \*

Please enter the wireless network password

Finish

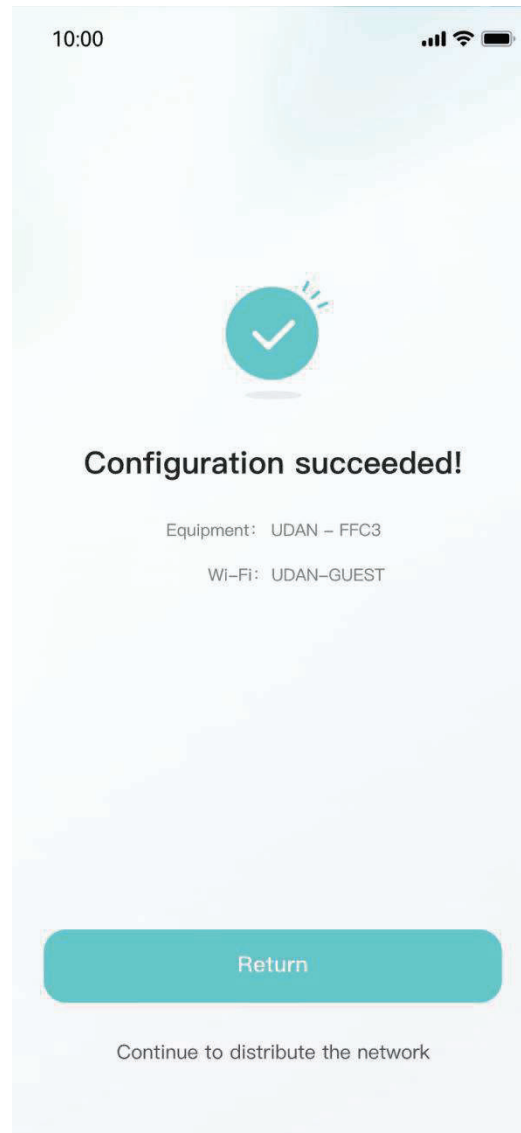

## 6.4. App page

### 6.4.1 Equipment

The device homepage is used to display the currently managed device information.

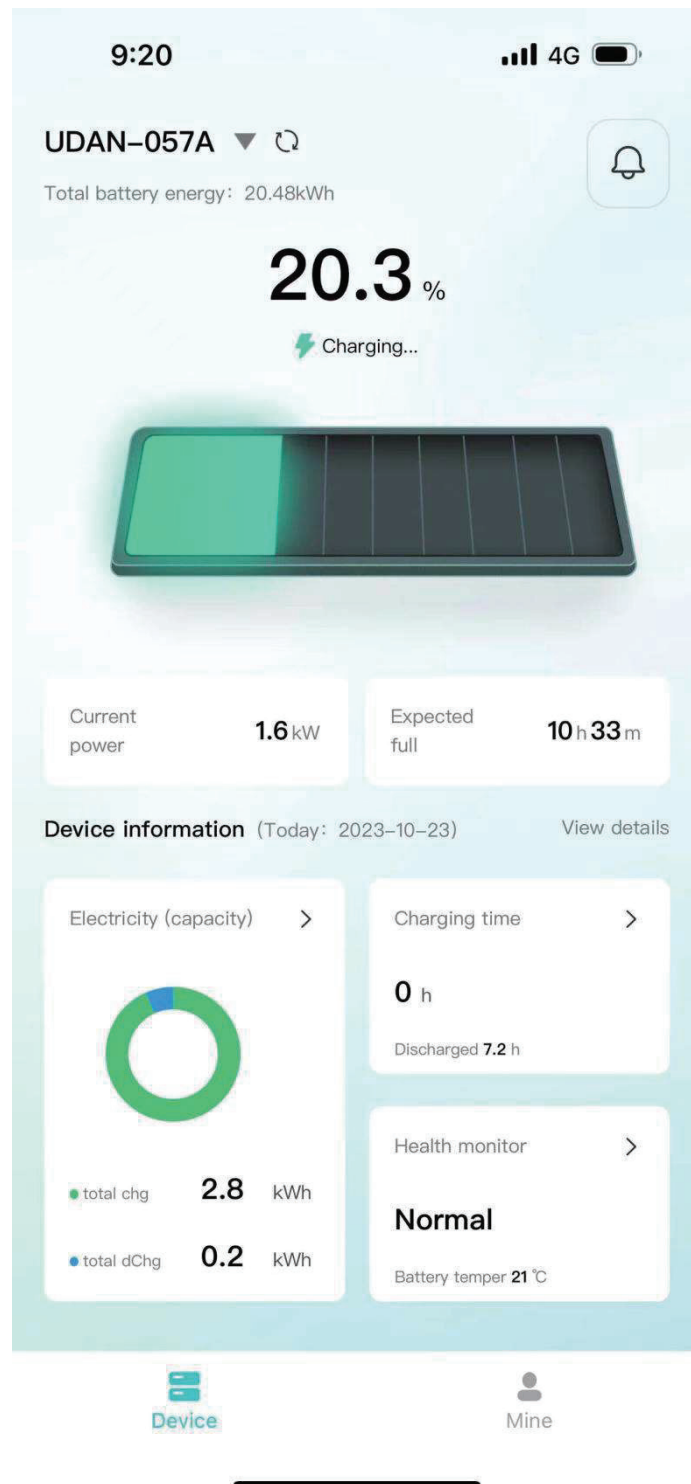

- The top area displays the device name, battery energy, and message entry.



- Middle area: Displays the current battery charging and discharging status, battery percentage, current power, and estimated full time.

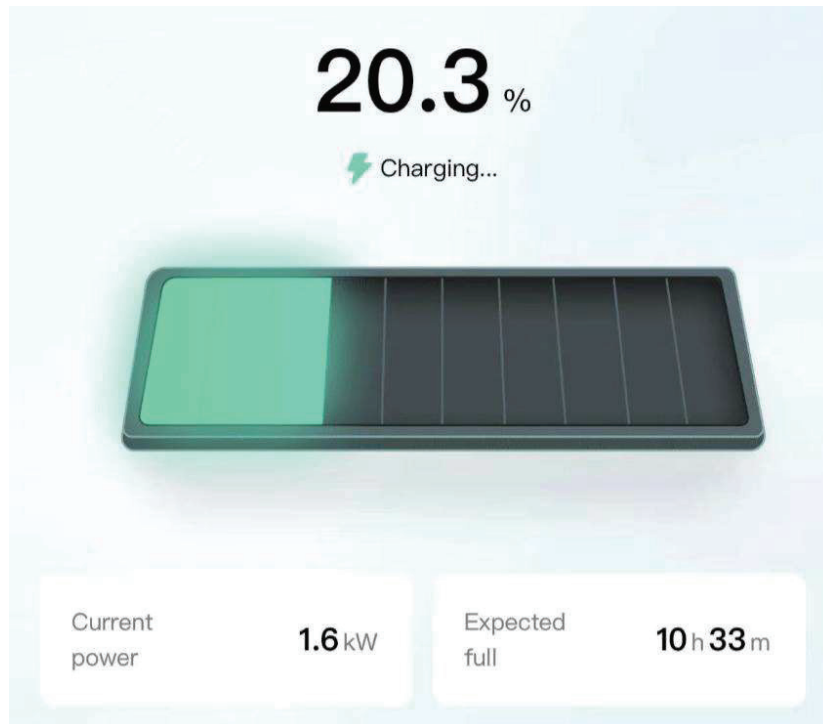

- The bottom area: Displays the device battery, charging time, and health check overview data of the day in the form of a card. You can click the corresponding card to view the details.

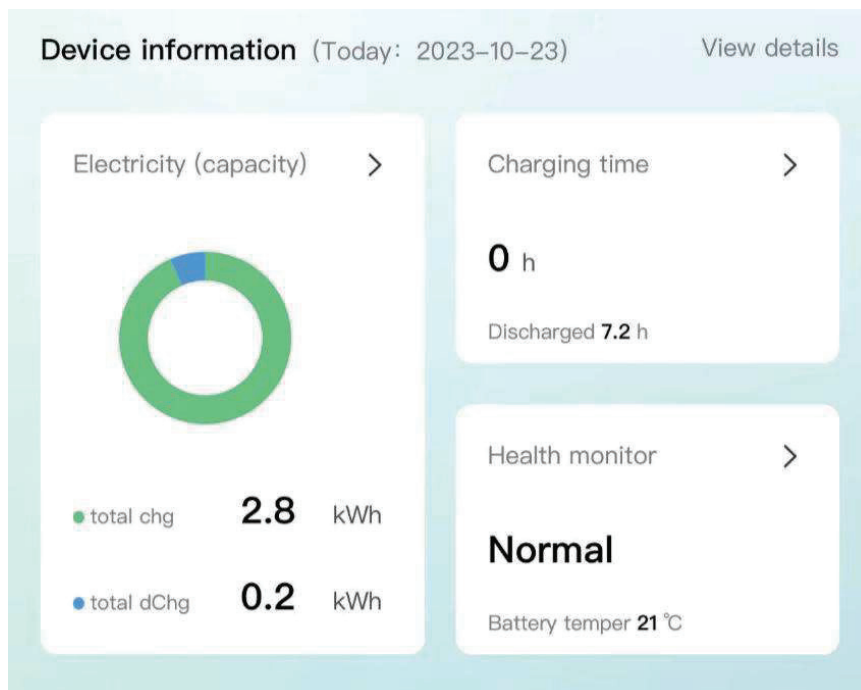

## 6.4.2 Data details

Display the data details of the current device, and view the battery, charging and discharging power, and charging and discharging time data separately, and support time filtering.

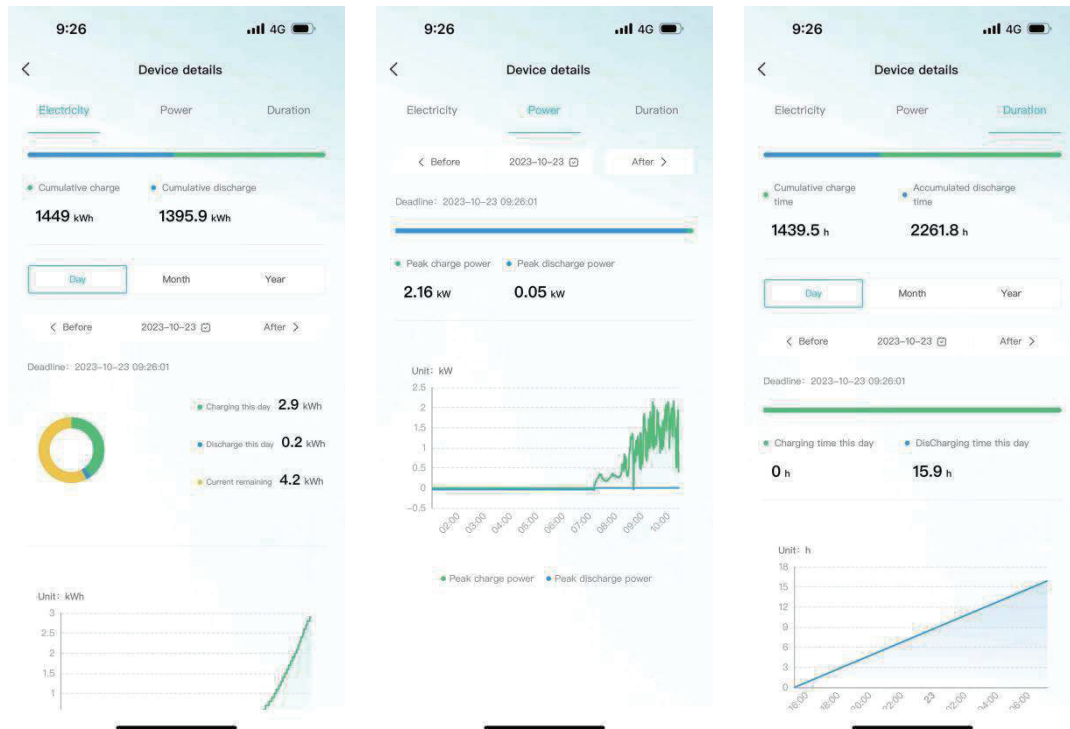

## 6.4.3 Mine

My page allows users to view **my devices**, **add devices**, **configure WiFi**, **software updates**, **after-sales services**, **problem feedback**, **app settings** .

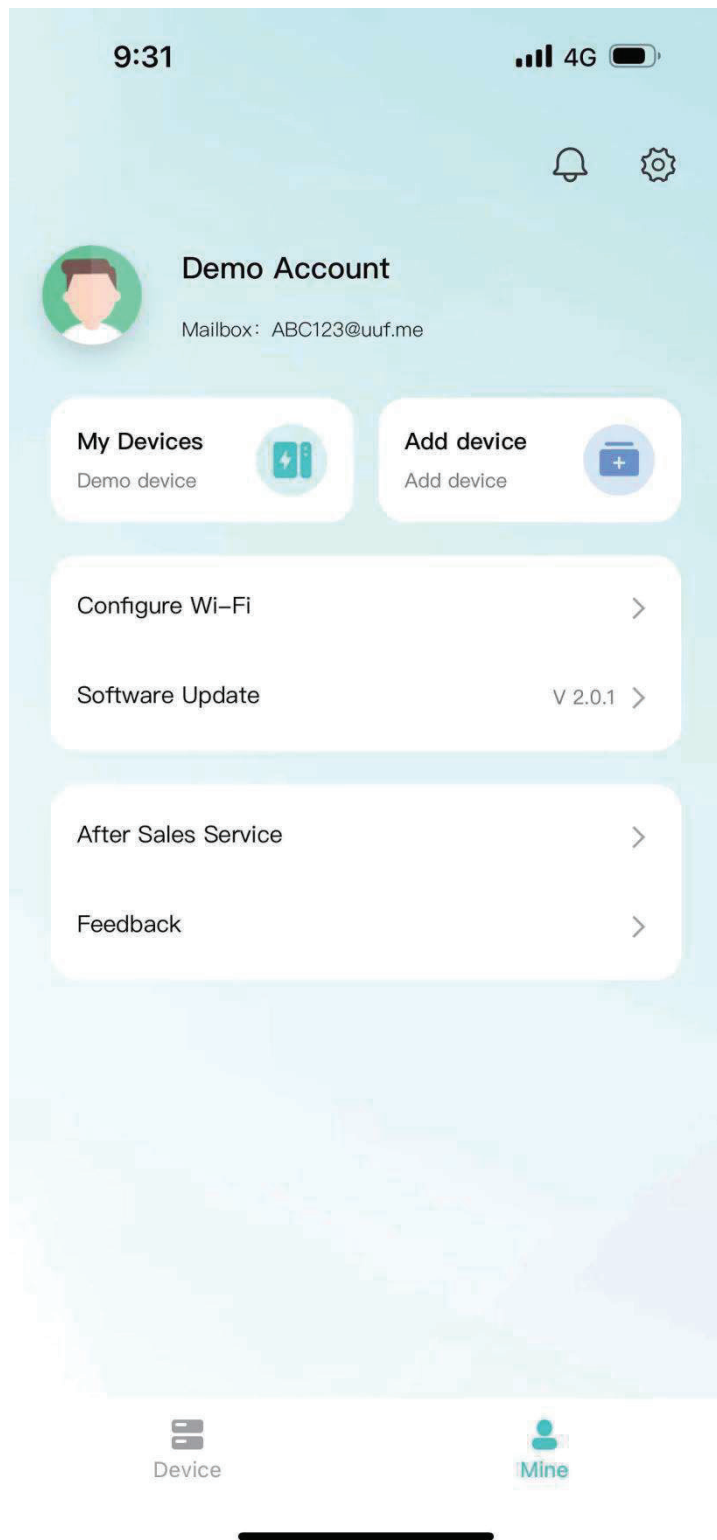

- Click "My Devices" to enter Facility Management. You can view all devices managed under the current account, switch devices displayed on the homepage, unbind devices, and other operations.

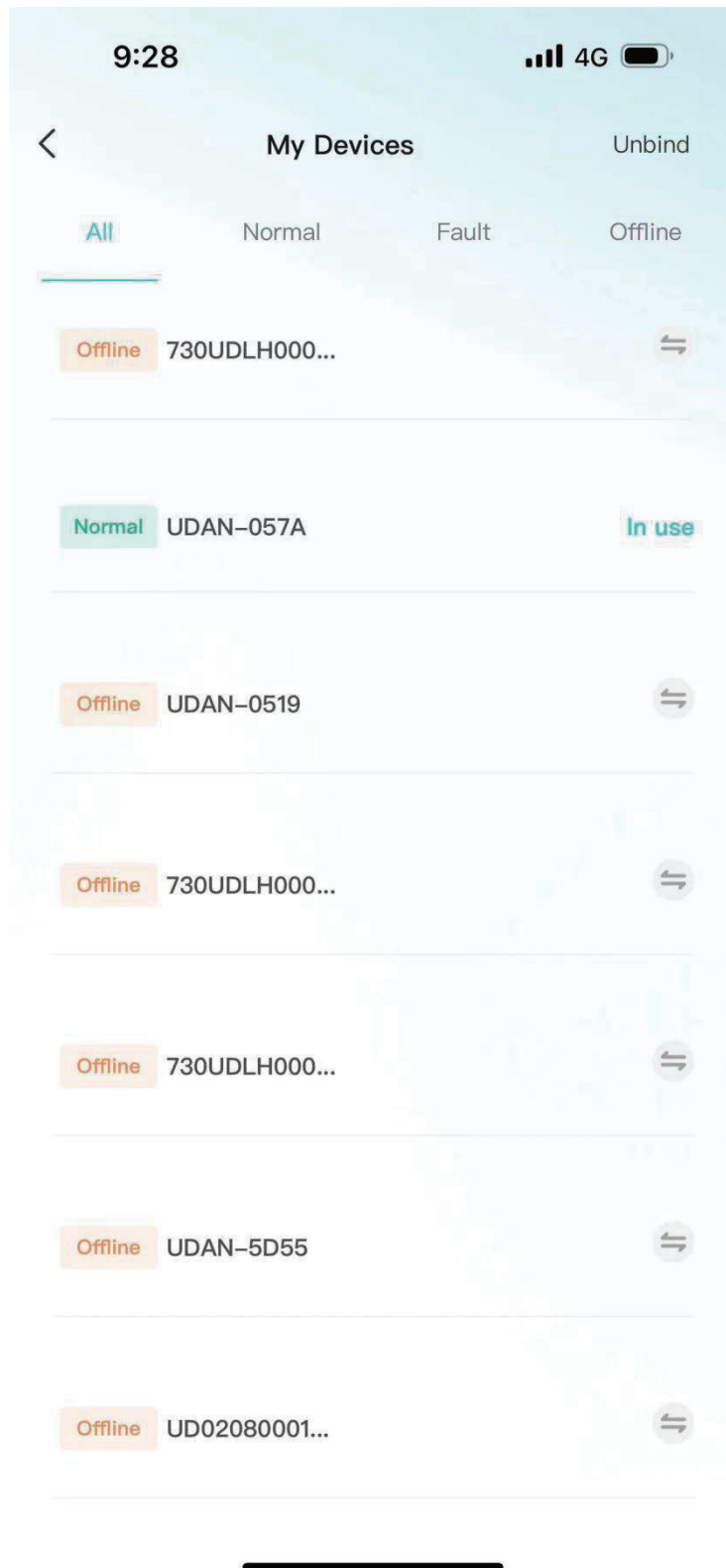

- Click "Add Device" to enter the code scanning page.
- Click "Equipment Distribution Network" to enter the equipment distribution

network process.

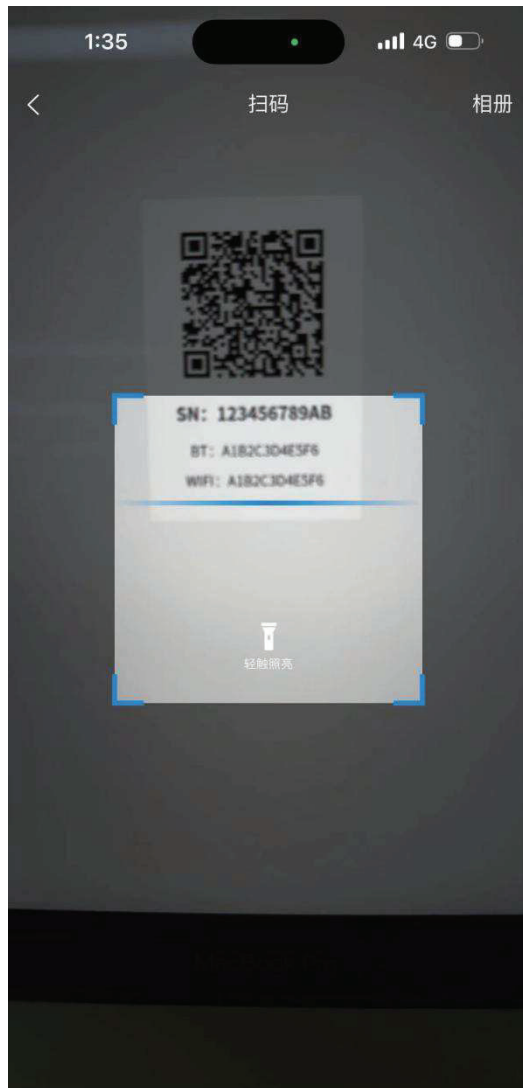

- After clicking "software update", it will enter the version detection. If there is a new version, it will be updated.
- Click "after-sales services" and enter the after-sales services page to display the after-sales services declaration of the current supplier.

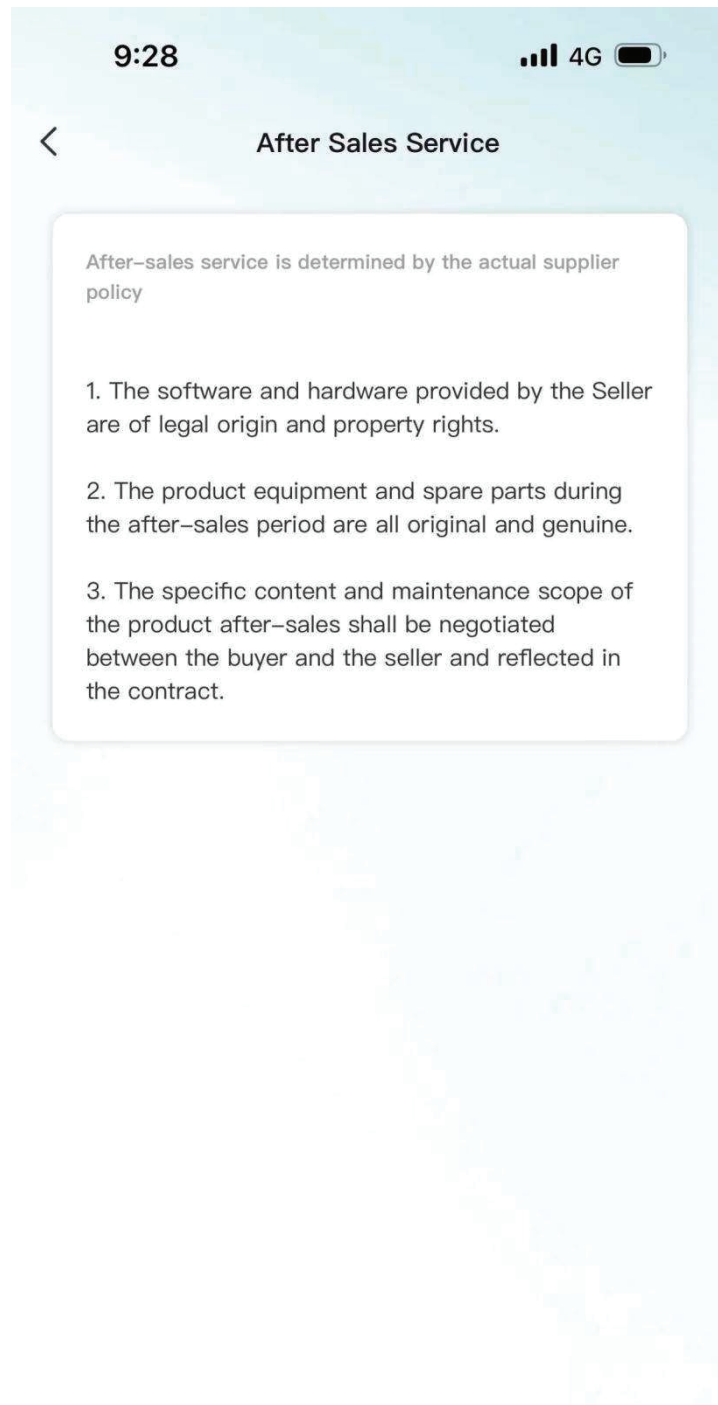

- Click "Feedback" to enter the feedback page. You can enter the current problem that needs feedback and submit it.

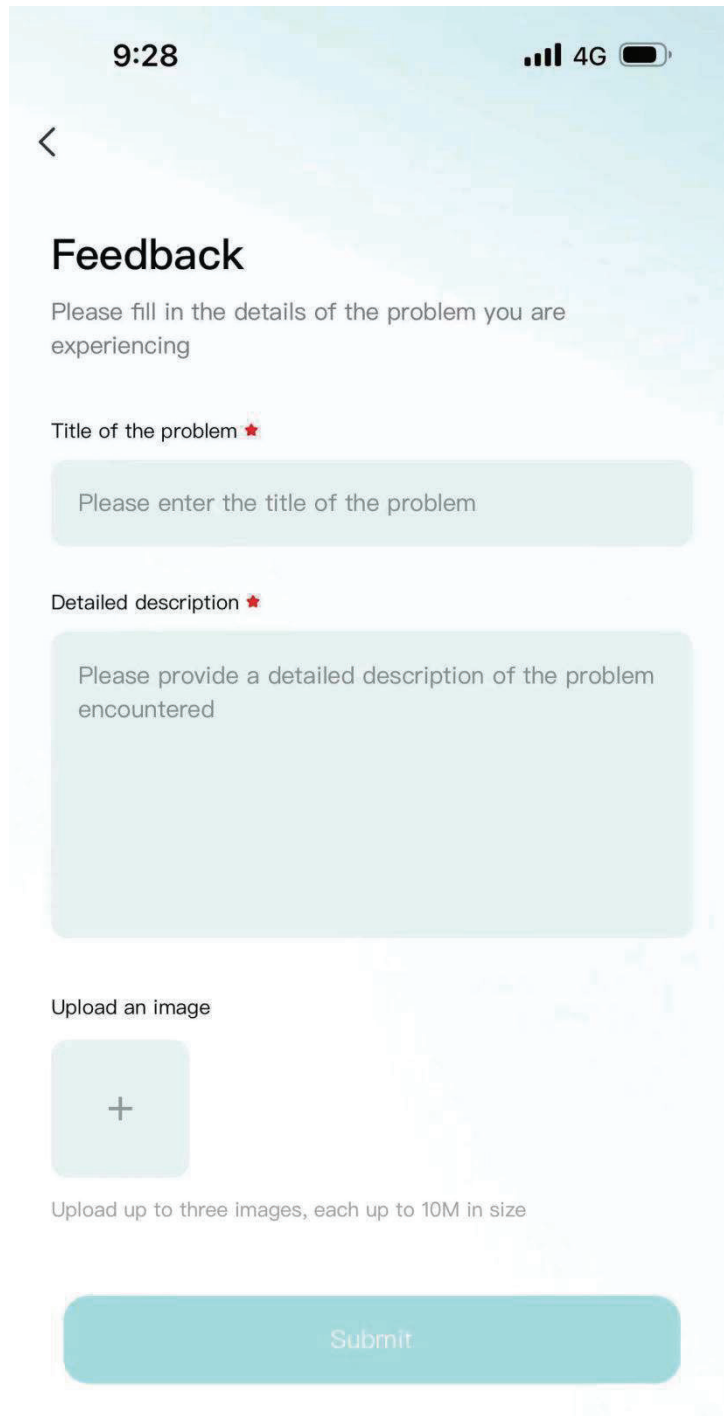

## 6.4.4 Message

Click on the device or my page, the message icon above, you can enter the inbox

page to view the current notification or chat history.

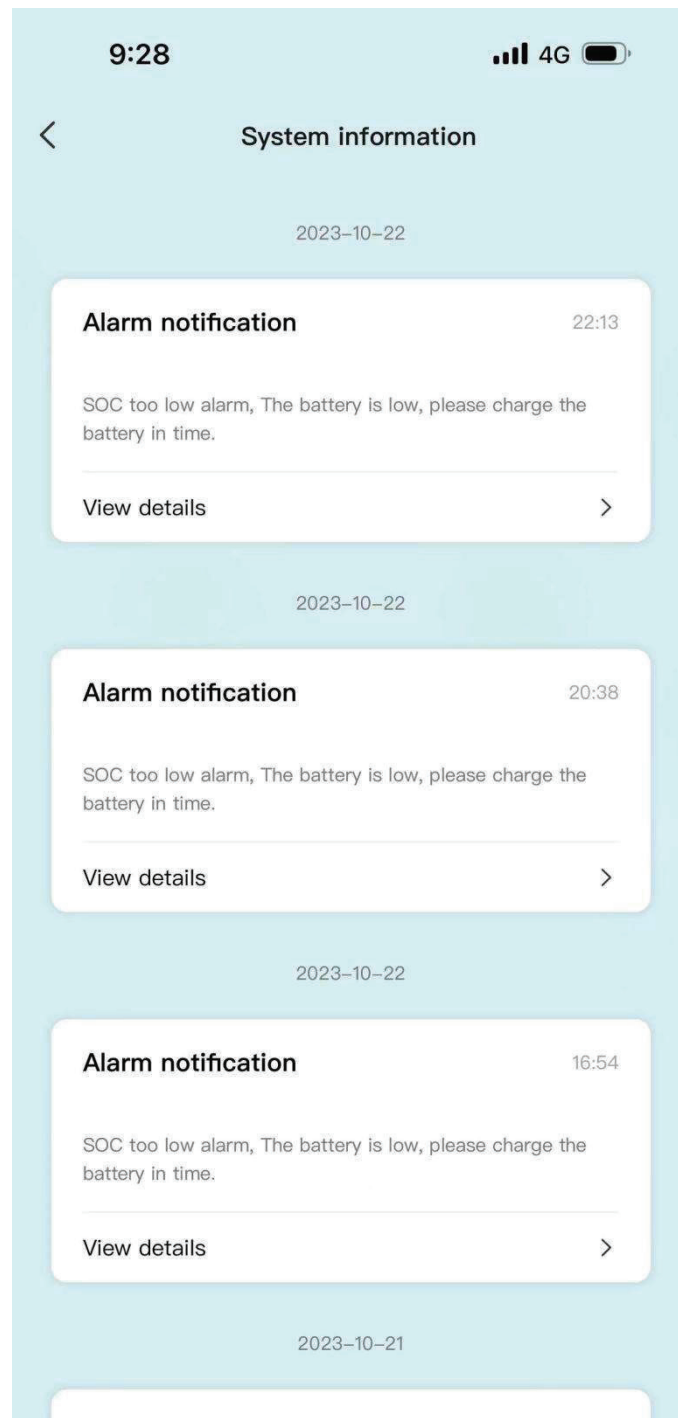

## 6.4.5 App settings

- Click My Pages - Settings icon in the upper-right corner to enter the App Settings page.

- Settings page support: language switching, Privacy Policy, cache cleaning, personal information, account and security.

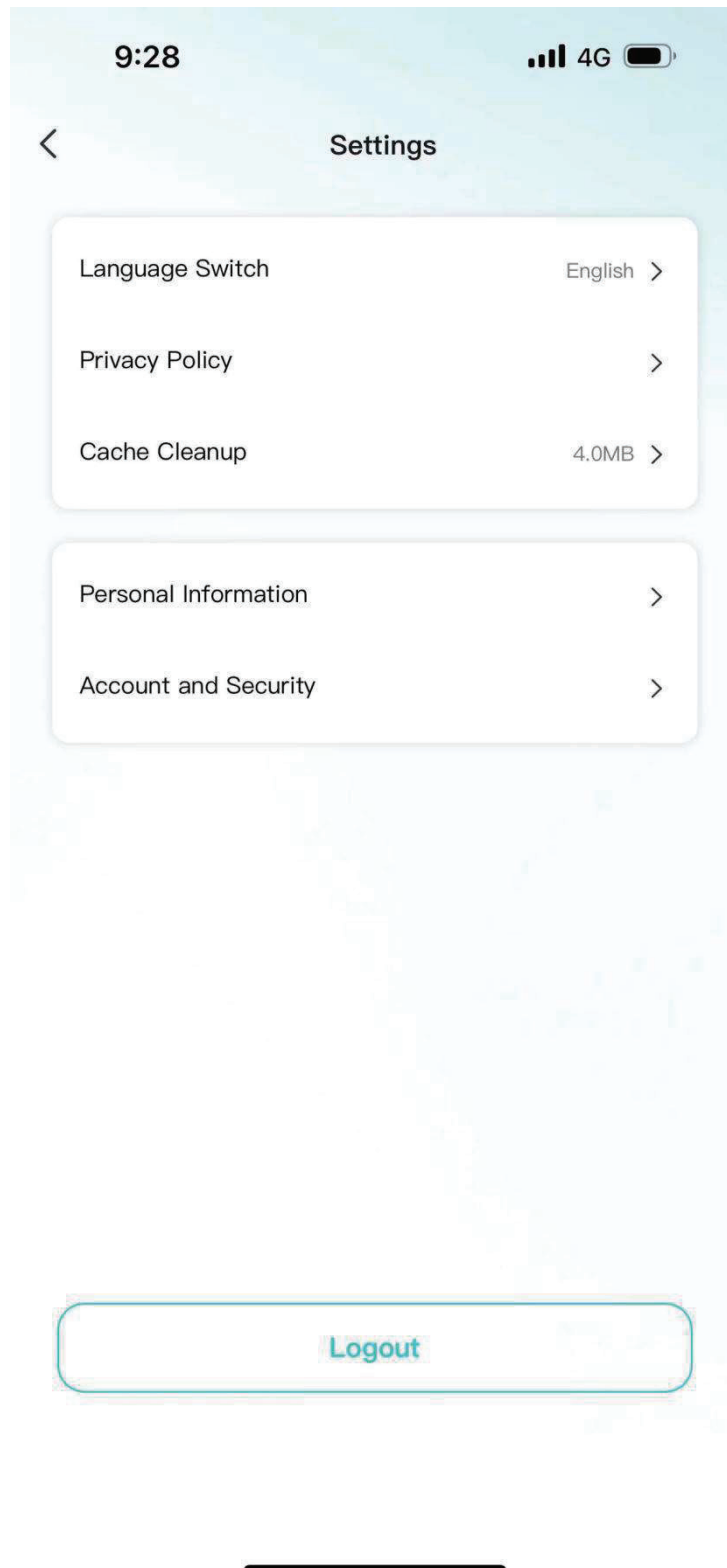

## 7 Maintenance



**Warning!** Improper decommissioning may cause damage to the equipment and/or battery inverter.

Before maintenance, ensure that battery is decommissioned according to relevant provisions.



Note: All maintenance work shall comply with local applicable regulations and standards.

**The USB-CAN port of battery has the functions of upgrading firmware and recording battery data, which can be used as an auxiliary tool.**

To ensure safe operation, all plug connections must be checked. If necessary, relevant operators shall press them back into place at least once a year.

The following inspection or maintenance must be carried out once a year:

- General visual inspection
- Check all tightened electrical connections. Check the tightening torque according to the values in the following table. Loose connections must be retightened to the specified torque.

Connection mode	Tightening torque
high-voltage BMS box grounding	4.5Nm
Fixing the lug of the high-voltage BMS box	1.2Nm
Fixing the lug of the battery module	1.2Nm

- Using the monitoring software, check whether the SoC, SoH, battery voltage and temperature of the battery module are abnormal.
- Shut down and restart battery once a year.

Note: If the system is installed in a polluted environment, maintenance and cleaning must be carried out at short intervals.

Note: Clean the battery rack with a dry-cleaning cloth. Ensure that no moisture comes into contact with the battery connections. Do not use solvents.



**Attention:**

1. Do not dispose of batteries and rechargeable batteries as domestic waste!

You are legally obliged to return used batteries and rechargeable batteries.

2. Waste batteries may contain pollutants that can damage the environment or your health if improperly stored or handled.

3. Batteries also contain iron, lithium and other important raw materials, which can be recycled.

**Do not dispose of batteries as household waste!**

