



BCP-A2M-P
(GBT Plug)

BCP-AT2M-P-16
(Type 2 &GBT Plug)

User manual

CONTENTS













1. Safety Information	P-01
• Important safety instructions	P-01
2. Product Introduction	P-02
• 2.1. Product Appearance	P-02
• 2.2. Parameter table	P-03
• 2.3. Features	P-05
• 2.4. Protection Functions	P-06
3. Installation Instructions	P-07
• 3.1. Installation Considerations	P-07
• 3.2. Minimum Installation Requirements	P-07
• 3.3. Position	P-08
• 3.4. Height	P-08
• 3.5. Power Supply	P-08
• 3.6. Accessories List	P-09
• 3.7. Installation Step	P-10
4. Operating instructions	P-12
• 4.1. Buttons On Charger	P-12
• 4.2. Buzzer	P-12
• 4.3. Dynamic Load Balancing Kit	P-12
• 4.4. LED Lights Display	P-13
• 4.5. Firmware Update via OCPP Server	P-17
5. Warranty	P-18
6. Manufacturer self-declaration	P-18

1. Safety Information





Important Safety Instructions

This document contains important instructions and warnings that must be followed when installing and maintaining the EV Charger.

Warning

-  Read this entire mandatory document before installing or using the EV charger.
-  This device should be supervised when used around children.
-  The BCP series EV Charger must be grounded through a permanent wiring system or an equipment grounding conductor.
-  Do not install or use the EV Charger near flammable, explosive, harsh, or combustible materials, chemicals, or vapors.
-  Use the EV Charger only within the specified operating parameters.
-  Never spray water or any other liquid directly at the wall mounted EV Charger. Never spray any liquid onto the charger handle or submerge the charger handle in liquid. Store the charger handle above the ground to prevent unnecessary exposure to contamination or moisture.
-  Stop using and do not use the EV Charger if it is defective, appears cracked, frayed, broken, or otherwise damaged, or fails to operate, or continue operation.
-  Do not attempt to disassemble, repair, tamper with, or modify the EV Charger. The EV Charger is not user serviceable. Contact us for any repairs or modification.
-  Transporting the EV Charger, handle with care. Do not subject it to strong force or impact or pull, twist, tangle, drag, or step on the EV Charger, to prevent damage to it or any components.
-  Do not touch the EV Charger's end terminals with sharp metallic objects, such as wire, tools, or needles.
-  Do not forcefully fold or apply pressure to any part of the EV Charger or damage it with sharp objects.
-  Do not insert foreign objects into any part of the EV Charger.
-  Use of the EV Charger may affect or impair the operation of any medical or implantable electronic devices, such as an implantable cardiac pacemaker or an implantable cardioverter defibrillator. Check with your electronic device manufacturer concerning the effects that charging may have on such electronic devices before using the EV Charger.

Cautions

-  Do not use private power generators as a power source for charging.
-  Incorrect installation and testing of the EV Charger could potentially damage either the vehicle's Battery and/or the EV Charger itself. Any resulting damage is excluded from New Vehicle Limited Warranty and the EV Charger Limited Warranty.
-  Do not operate the EV Charger in temperatures outside its operating range of -30°C to +50°C.
-  That adaptors or conversion adapters are not allowed to be used.
-  That cord extension sets are not allowed to be used.

Notes

- ⚠ Ensure that the EV Charger's charging cable is positioned so it will not be stepped on, driven over, tripped on, or subjected to damage or stress.
- ⚠ Do not use cleaning solvents to clean any of the EV Charger's components. The outside of the EV Charger, the charging cable, and the connector end of the charging cable should be periodically wiped with a clean dry cloth to remove accumulation of dirt and dust.
- ⚠ Be careful when removing the power entry knock-out.



2. Product Introduction



2.1. Product Appearance



1	Emergency Button Switch (When the button is pressed, the EV Charger will stop, then rotate the button pop-up reset.)
2	Function test button (For leakage test.)
3	RFID
4	LED light

2.2. Parameter table

Wallbox Models	BCP-A2M-P	BCP-AT2M-P
		
Maximum Power	7.4KW	22KW
Input voltage/Output voltage	AC230 1-Phase	AC400 3-Phase
Input frequency	50Hz/60Hz	
Tethered/Socket	Tethered	
Meter	Metering Chip	
Display	LED Lights	
Rate Charging Current	6-32A	
Cable Length	5m	
Standby Power Consumption	2W	
Operating Temperature	-30°C ~ 50°C	
Storage temperature	-40°C ~ 85°C	
Operating Humidity	5%-95%	
IP Protection	IP65	
Safety Protection	Leakage Protection, Over Current Protection, Ground Protection, Over Voltage Protection, Under Voltage Protection, Contactor Adhesion Protection, Neutral and Live Wire Reverse Connection Protection, Over Temperature Protection, CP Signal Abnormal Protection, Lightning Protection	
Operating Altitude	≤2000m	
Charger Dimension (H*W*D)	381mm*230mm*122mm	
Gross Weight	6Kg	7Kg
Leakage Detection	TYPE A+DC6mA leakage sensor built-in	

Wallbox Models	BCP-A2M-P-16	BCP-AT2M-P-16
		
Maximum Power	3.7KW	11KW
Input voltage/Output voltage	AC230 1-Phase	AC400 3-Phase
Input frequency	50Hz/60Hz	
Tethered/Socket	Tethered	
Meter	Metering Chip	
Display	LED Lights	
Rate Charging Current	6-16A	
Cable Length	5m	
Standby Power Consumption	2W	
Operating Temperature	-30°C ~ 50°C	
Storage temperature	-40°C ~ 85°C	
Operating Humidity	5%-95%	
IP Protection	IP65	
Safety Protection	Leakage Protection, Over Current Protection, Ground Protection, Over Voltage Protection, Under Voltage Protection, Contactor Adhesion Protection, Neutral and Live Wire Reverse Connection Protection, Over Temperature Protection, CP Signal Abnormal Protection, Lightning Protection	
Operating Altitude	≤2000m	
Charger Dimension (H*W*D)	381mm*230mm*122mm	
Gross Weight	5Kg	6Kg
Leakage Detection	TYPE A+DC6mA leakage sensor built-in	

2.3. Features

- Connectivity: Ethernet and WIFI connection
- App Remotes: Remotely control the charger and have the charging history.
- Full Protection: For people's safety
- IP65 level protection
- Leakage Protection: with Type A sensor + DC6mA sensor
- Temperature Protection: Stop operating once over temperature.
- Operating Temperature: -30°C~+50°C



Wi-Fi

Operating Frequency Range	2412 - 2484MHz
Wi-Fi Protocols	IEEE 802.11 b/g/n
Channels	14
TX Power	18.5~20.5dBm
EIRP	0.459
TX bandwidth	20MHz/40MHz
Modulation type	OFDM & DSSS
Transmitting Duty Cycle	10%



Bluetooth BLE

Sensitivity @30.8% PER	-93 dBm
Co-channel C/I	+10dB
RF Power Control Range	-12 ~ 9dbm



NFC

Modulation Type	ASK
Operating Frequency	13.56MHz
H-field strength	13.29 dBuA/m@3m distance
Antenna Type	PCB antenna (coil)



LoRa





Operating frequency band	433.05~ 434.79MHz
EIRP	22dBm

2.4. Protection Functions

With full protection to avoid all kinds of charging safety hazards, it will automatic power off after the vehicle is fully charged, to protect the car battery and prolong the working life.



Warning

-  Normally, the earth wire should be properly connected, otherwise the EV charger will not work.
-  For situation where there is no earth connection, in order to enable the EV Charger to operate, it can be set via APP to turn off the earth detection and it will work, but it will reduce to the leakage protection safety level.
-  This BCP series AC EV charger must be grounded via a permanent electrical system or equipment grounding conductor.
-  Before installing an AC EV charger, please confirm the type of grid connection available. If you are unsure of the type of connection available on the service panel, please consult an electrician or contact us for assistance.
-  Note: Please consult your local electrician or refer to your local code in order to choose the proper wire for the AC EV charger current.

3. Installation Instructions

3.1. Installation Considerations

- Note: Throughout the manual, "conduit" is used as the standard term for the protective tubing that houses the service wiring. In regions where conduit is not used (Europe for example), a cable comprised of service wiring enclosed in a protective jacket may be substituted for conduit if allowed by local regulations.
- Here are some additional guidelines
- Conduit needs to be metal and flame retardant.
- Use an appropriate circuit breaker.
- To keep the housing weatherproof, use cable glands.

3.2. Minimum Installation Requirements

Installation of the wall charger requires that you:

- Calculate the existing electrical load to determine the maximum operating current.
- Calculate the distance to ensure minimal voltage drop.
- Obtain any necessary permits from the local authority that has jurisdiction and confirm that the follow-up inspection has been scheduled by an electrician after the installation is complete.
- Use only copper conductors.
- Use copper wire that meets the specifications of local wiring regulations. The selected cable must be capable of withstanding continuous loads of up to 40A at all times. The selected circuit protection device must incorporate an appropriate wall-mounted residual current device (RCD) and corresponding electrical load over current protection.

3.3. Position

- Ensure that the parking position is within range of the charging cable.
- There is enough clearance for the charging cable to wrap around and the charging handle can be comfortably positioned on the side of base.
- If installed in an enclosed garage, choose to install on the side of the EV charger slot.
- For outdoor installations, waterproof protection is recommended but not mandatory.
- Install in a well-ventilated space. Avoid installation in enclosed boxes or close to high power appliances.

3.4. Height

- Maximum height (indoor and outdoor): 60 inches (1.5 m)
- Recommended height: 47 in (~1.2 m)
- Minimum outdoor height: 24 in (0.6 m)
- Minimum interior height: 18 inches (0.45 m)

3.5. Power Supply

230V single-phase power supply

- For single-phase EV charger, a single-phase wire (L), Neutral and earth wire must be connected. The phase voltage between the Line and Neutral wires should be 230V.
- For 3-phase EV charger, connect the single phase wire (L1), the neutral wire and the earth wire do not connect the other phase wires (L2 or L3). The phase voltage between the line and neutral wires should be 230V.

400V three-phase power supply with neutral line

- If three phases are applied, all three phases (L1, L2 and L3) and the neutral line should be connected to each other and the voltage of each phase to the neutral line should be 230V.

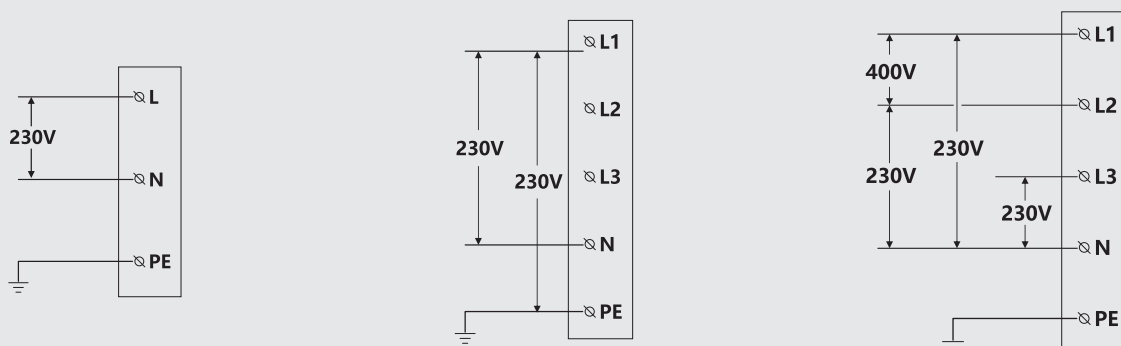

3.6. Accessories List

①



EV charger

X1

②

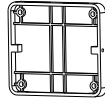

Mounting bracket

X1

③



RFID card (optional)

X2

④



M4.2*9.5
Fixing Screw

X1

⑤



8*40 socket head
screws and anchorings

X4

⑥



Wireless DLB box (optional)

X1

⑦

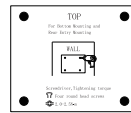

Positioning template

X1

⑧



One-Page QR Code Guide
& Manual

X1

⑨



Power Cable
Crimp Terminal

X6

Note: Card type supported by RFID: RF card ISO14443 Type A, MIFARE® ONE (MF1) card, with the read-write frequency of 13.56MHz±7K.

3.7. Installation Step

3.7.1. Step-by-step Installation Instructions

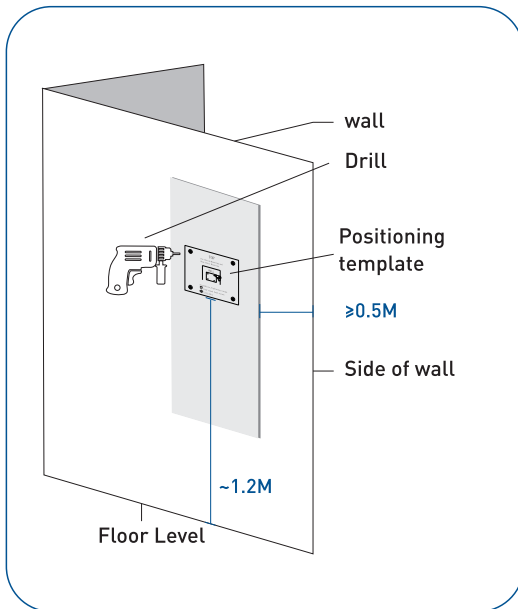

Step 1

Position

The bottom of the positioning plate is 1.2 m away (recommended), if the EV charger is installed close to the edge of the wall, the positioning plate should be more than 0.5 m away from the edge of the wall.

Drilling pilot holes

Drilling the holes according to the instruction on the Positioning template for different installation and wiring ways.

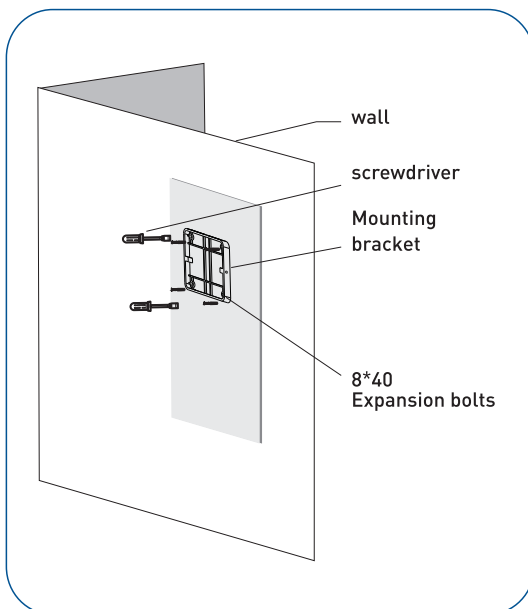

Step 2

Install the Mounting bracket

Put the 8*40 Socket head screws^{*} anchoring into the holes, and use the screw driver make the 4pcs 8*40 Socket head screws to fix the Mounting bracket on the wall .

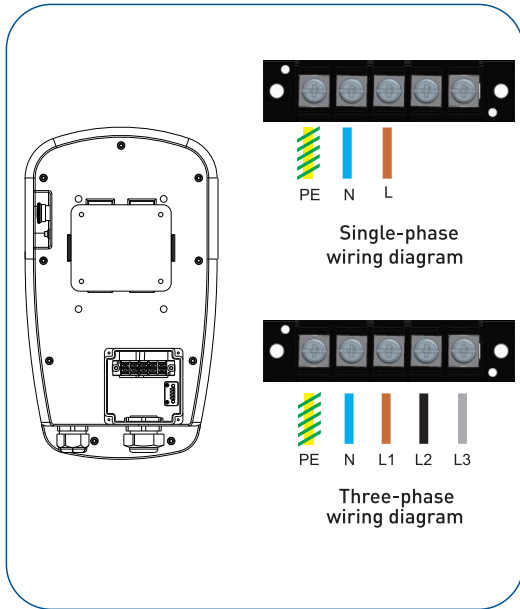

Step 3

Wiring

Note: Consult with your local electrician or refer to your local code for proper wire sizing appropriate for the currents in your EV Charger.

Note: It is the installer's responsibility to identify whether additional grounding is required to ensure that local regulations are met. Grounding must be installed at the power source and not at the cable entry to the EV Charger.

As the picture at left shows, Use the screwdriver to loosen the screws of the wiring port on the rear cover of the EV charger. Wire the cable to the according terminal.

After completing the wiring, reinstall the cover of the wiring port onto the EV charger.

Note: The torque applied to the terminal screws shall be 1.4 N·m to 1.6 N·m.

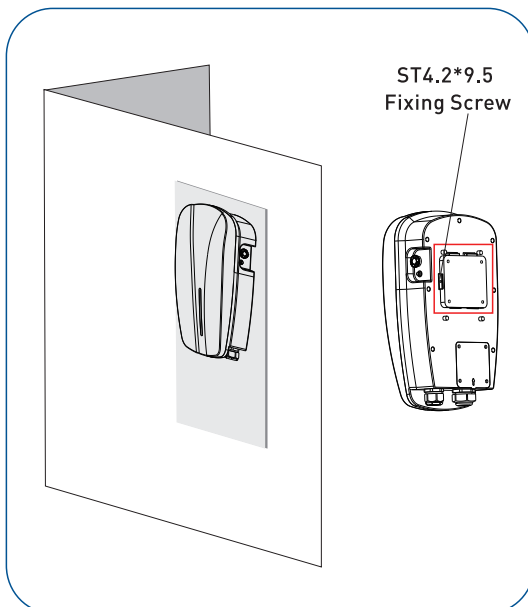

Step 4

Install the EV Charger to the mounting bracket

Align the back of the EV charger with the sides of the bracket. After a complete fit, insert the top pin at the back of the charging pile downward into the mounting bracket.

Installation

Use the 1pcs ST4.2*9.5 screw to fix the EV charger to the mounting bracket (Screws torque 1.5NM-2.0NM).

3.7.2. Set the Operating Current

- After installation, users can set the maximum operating current of the EV charger in the APP, Please refer to APP manual for details.

4. Operating instruction

4.1. Buttons On Charger

- Emergency stop button

Press	Stop the charging
Button ejecting	Fixing faults
Button ejected	In operating

- Function test button

Press	Leakage test
-------	--------------

- Rest button on PCB Long press for 5s Reset the charger password (Wi-Fi Ap Password and OCPP configuration Password)
- To restore the charger to be default settings, after press the emergency stop button and long press the reset button for 20S to achieve.
- Press the emergency button while powering on again the EV charge. Then start the OCPP configuration process.





4.2. Buzzer

Swipe the RFID card to start the authentication successfully	One Short Beep
Swipe the RFID card to stop the authentication successfully	Two Short Beeps
RFID card authentication failed	Five Short Beeps
Enter server configuration mode	One Long Beep
Server parameters are configured successfully	One Long Beep
Server parameter configuration failed	Two Short Beeps
Leakage test in progress	One Long Beep

4.3. Dynamic Load Balancing Kit

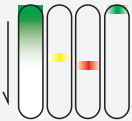
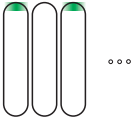

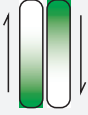

- The Dynamic Load Balancing Kit is suitable for home charging use. Connect the DLB kit with the charger, to active the DLB function automatic. Disconnect the DLB kit with the charger, to off-line the DLB function automatic.

4.4. LED Lights Display



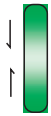



Normal Status				
LED Behavior	LED Status	Status Description	Potential Cause	Solution
	Lights OFF	No power supply	No power	Check the power source
	The green lights light up in sequence from top to bottom, then the yellow and red lights light up in sequence until the first green light blinks	Charger Power ON self test		
	The first green light slow blinking (ON for 1 second, OFF for 1 second)	Network is not connected	Wi-Fi connection failure or wrong password	1.WPA 2_Enterprise is not available for charger 2.Ensure password is correct 3.Restart the APP
	The first light is in the green breathing light state	Standby in the default state		
	The first light is in the blue breathing light state	Standby in OCPP mode (Wi-Fi, Ethernet)		
	The first green and the last green lights slow blinking. (ON for 1 second, OFF for 1 second)	The charger is reserved		
	The 1-6 green lights ON, brightness decreases from top to bottom	Charger authorized, waiting for the Charging Connector plug in		
	Green lights up and down	The Charging Connector is plugged in, waiting for RFID card authentication		

Note : LED light in blue for standby status is only adapted to the charger which is produced after June 2024.





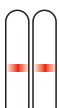

Normal Status

LED Behavior	LED Status	Status Description	Potential Cause	Solution
	Green lights end in the middle	Waiting for the car start to charge		
	Green lights extend from the middle to the ends	Charging		
	All green lights ON	Charging finished		
	Yellow lights flashing	Charger is remotely disabled or not registered	Charger is not configured	Configure the charger

Fault Status

LED Behavior	LED Status	Status Description	Potential Cause	Solution
	All lights strobe (4 times per second)	Contactor failure	Contactor adhesion or tripping	Check whether the vehicle charging module is normal
	Yellow lights ON	Emergency stop protection	Emergency stop button is pressed	Rotate the emergency stop button Pop-up reset
	Red lights ON	Grounding abnormality	The ground wire is not wired or the neutral wire is reversed	Check whether the grid connection and charger wiring is correct
	Red light once	Over Voltage	Power supply has short circuit or unstable	1.Check the power supply 2.Check the wire of power supply
	Red light twice	Under Voltage	Power supply voltage is insufficient	1.Check the power supply 2.Check the wire of power supply
	Red light thrice	Leakage fault	Leakage happens	1.Reset with emergency stop button 2.Check the charger connector or vehicle for leakage

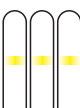
Fault Status

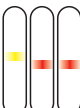
LED Behavior	LED Status	Status Description	Potential Cause	Solution
 ...	Red light flashes continuously (Once per second)	Over current	Short circuit may happen	Call for professional repair
 ...	Red light flashes (Quartic per second)	Over temperature alarm	High temperature	1.Wait for charger cooling 2.Ensure the wiring of charger terminal is not loosing
 ...	Alternating red and yellow continuously Red for 0.5 seconds followed by yellow for 0.5 seconds	Abnormal CP signal	The connection between the charger and the vehicle is loose	1.Check if the connector is with water leakage in 2.Ensure the connector is matched with EV
	Red and yellow lights flash once	Abnormal CC signal	The connection between the charger and the vehicle is loose	Check whether the charger connector is firmly inserted
	Yellow light ON triple	LED board is offline	LED board is fault or loosing	Open the charger cover and check whether the light board cable is connected correctly and firmly
	Yellow light ON once, red light ON once	DLB is offline	The DLB connection is loose	Check the connection between DLB box and charger
	Yellow light ON once, red light ON twice	DLB abnormal	The connection between the DLB box and the CT is loose or the CT is not clamped	1.Check the CT of the DLB box is in the correct position 2.Check whether the DLB box CT is firmly clamped 3.Check if the phase sequence of the DLB box CT is correct 4.Check if the connection between the DLB box CT and the DLB box is firm

4.5. Firmware Update via OCPP Server

The server sends a firmware upgrade command to the EV charger in the background, and when the set time comes, the firmware starts to download.

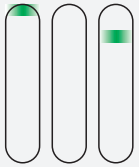

The first and second green lights flash alternately

or other operating status



Download firmware



Green light circularly flows from top to bottom

or other operating status



If the EV charger is charging, install the firmware after the charging is completed.



Extend from the middle to the ends



End charging



All green lights on



Install firmware



The yellow light lights up three times



The update is complete, ready to reconnect to the network

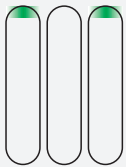

Green light No. 1 flashes slowly (on for 1 second, off for 1 second).



Network connection is successful.



Green Light No. 1 breathing

or other operating status

5. Warranty

In order to ensure the normal service life of charging piles and reduce the risks in use, maintenance must be done within the specified time by professionals with accredited safety maintenance tools.

- Three-year free warranty is provided for any damage or malfunction caused by quality problems from the date of production of the charger.
- Damage caused by operation failure, natural force majeure, incorrect installation or instructions for use is not covered.
- Repair can only be performed by professionals. If any problem occurs during installation or use, contact your dealer first.

6. Manufacturer self-declaration

1. In order to improve the stability of the charger, we will provide software updates for at least three years from the date of manufacture of the charger.
2. The charger will not collect and save users' sensitive personal data, such as payment information, timestamped location data, audio input stream or biometric data.
3. The manufacturer will not collect telemetry data of the charger through remote service.